

Digital Multi Switcher

MSD-62 Series

MSD-6203/MSD-6204

<Command Reference Guide>

Ver.1.3.0

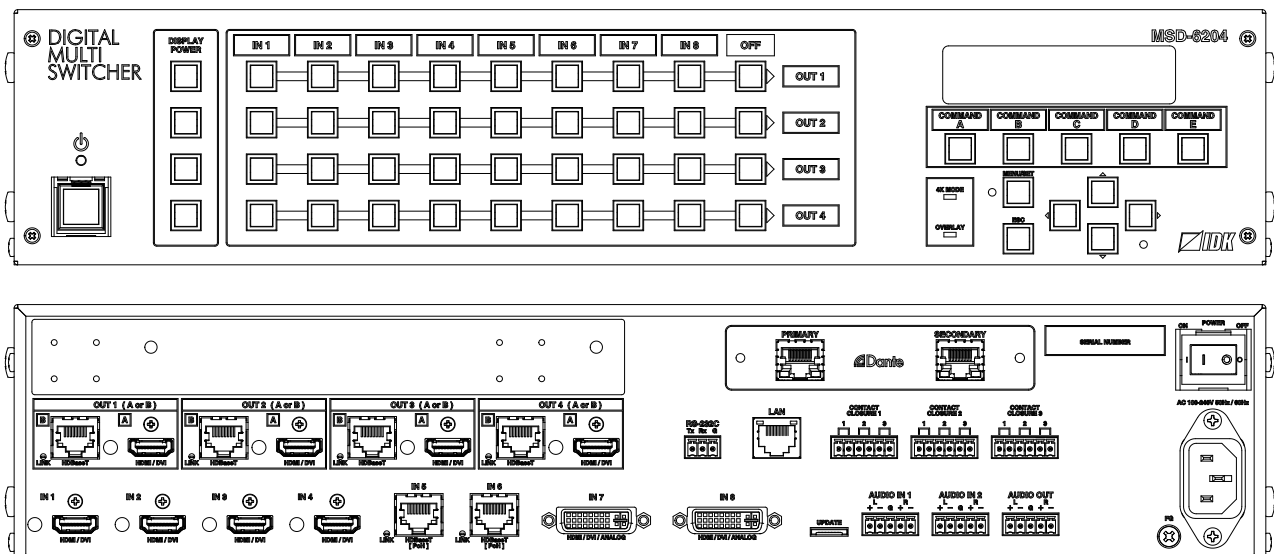

- Thank you for choosing our product.
- To ensure the best performance of this product, please read this user guide fully and carefully before using it and keep this manual together with the product for future reference as needed.

Trademarks

- HDBaseT™ and the HDBaseT Alliance Logo are trademarks of the HDBaseT Alliance.
- The terms HDMI and HDMI High-Definition Multimedia Interface, and the HDMI Logo are trademarks or registered trademarks of HDMI Licensing Administrator, Inc. in the United States and other countries.
- SDVoE™ and SDVoE logo are trademarks of SDVoE Alliance.
- All other company and product names mentioned in this document are either registered trademarks or trademarks of their respective owners. In this document, the “®” or “™” marks may not be specified.
- ©2018 IDK Corporation, all rights reserved.

Before reading this manual

- All rights reserved.
- Some information contained in this User guide such as exact product appearance, diagrams, menu operations, communication commands, and so on may differ depending on the product version.
- This User guide is subject to change without notice. You can download the latest version from IDK's website at: www.idkav.com

The reference manual consists of the following two volumes:

- User guide: Please download the command guide from the website above.
Provides explanations and procedures for operations, installation, connections among devices, I/O adjustment and settings.
- Command guide (this document):
Provides explanations and procedures for external control using RS-232C and LAN communications.

Table of Contents

| | | |
|--------|--|-----|
| 1 | About this Guide | 5 |
| 2 | Communication configuration and Specifications | 6 |
| 2.1 | RS-232C communication | 6 |
| 2.1.1 | Connecting RS-232C cable..... | 6 |
| 2.1.2 | RS-232C communication specification | 6 |
| 2.1.3 | Setting up RS-232C communication..... | 7 |
| 2.2 | LAN communication..... | 8 |
| 2.2.1 | LAN connector specification..... | 8 |
| 2.2.2 | LAN communication specification | 8 |
| 2.2.3 | Setting up LAN communication..... | 9 |
| 2.2.4 | The number of TCP-IP connections..... | 11 |
| 3 | Command..... | 12 |
| 3.1 | Command outline..... | 12 |
| 3.2 | Command list | 13 |
| 3.3 | Detailed descriptions | 18 |
| 3.3.1 | Error status..... | 18 |
| 3.3.2 | Power status | 19 |
| 3.3.3 | Input channels..... | 19 |
| 3.3.4 | Position, size, and masking..... | 21 |
| 3.3.5 | Video processing..... | 33 |
| 3.3.6 | Image quality | 35 |
| 3.3.7 | Input settings..... | 40 |
| 3.3.8 | Input timing..... | 45 |
| 3.3.9 | Output settings | 52 |
| 3.3.10 | Audio | 62 |
| 3.3.11 | EDID..... | 70 |
| 3.3.12 | RS-232C communication | 77 |
| 3.3.13 | LAN communication | 81 |
| 3.3.14 | Control commands | 85 |
| 3.3.15 | Preset memory..... | 99 |
| 3.3.16 | Bitmap | 105 |
| 3.3.17 | Other settings..... | 112 |

1 About this Guide

This guide contains the procedure for controlling the MSD-62 series using commands via RS-232C communication or LAN communication.

■ You can perform the following operations using communication commands.

- Switching channels.
- Setting I/O, audio, and EDID.
- Setting sending of external control command.
- Setting preset memory.
- Setting and displaying bitmaps and others

2 Communication configuration and Specifications

2.1 RS-232C communication

2.1.1 Connecting RS-232C cable

The MSD's RS-232C connection is supported by a 3-position terminal block.

Insert and secure the wires from the RS-232C cable into the supplied 3-position terminal block, and then insert the terminal block into the mating connector on the MSD.

AWG28 to AWG16 conductor gauge is recommended. The recommended wire strip length is 0.28 in. (7 mm). Short RTS/CTS and DTR/DSR as needed.

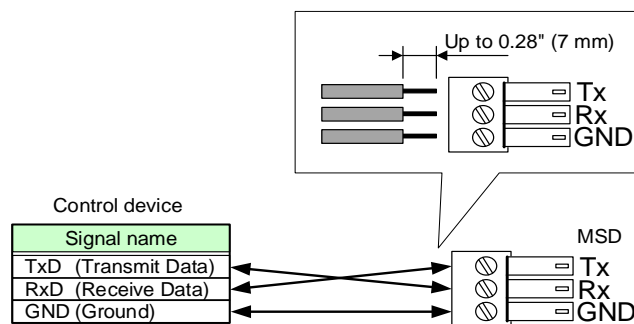

[Fig. 2.1] Connecting RS-232C cable into 3-position terminal block

2.1.2 RS-232C communication specification

[Table 2.1] RS-232C specification

| | |
|-----------------------|---|
| Standard | RS-232C |
| Baud rate [bps] | 4800/9600/19200/38400 [bps] |
| Data bit length [bit] | 7/8 |
| Parity check | NONE, EVEN, ODD |
| Stop bit [bit] | 1/2 |
| X parameter | Invalid |
| Flow control | None |
| Delimiter | CR LF (Carriage return and line feed, 0D and 0A in hex) |
| Communication method | Full duplex |

2.1.3 Setting up RS-232C communication

- (1) Connect the MSD and the control device via an RS-232C cable.
 - (2) Set the RS-232C communication as follows:
 - RS-232C communication: Baud rate, data bit length, parity check, and stop bit
 - Operation mode of RS-232C communication: "RECEIVER"
- 【Reference: User Guide】
- (3) For the control device, set the same values in the same way as RS-232C communication (baud rate, data bit length, parity check, and stop bit) in step (2) above.
 - (4) Send a communication command from the control device to the MSD in order to check the control status of the MSD.

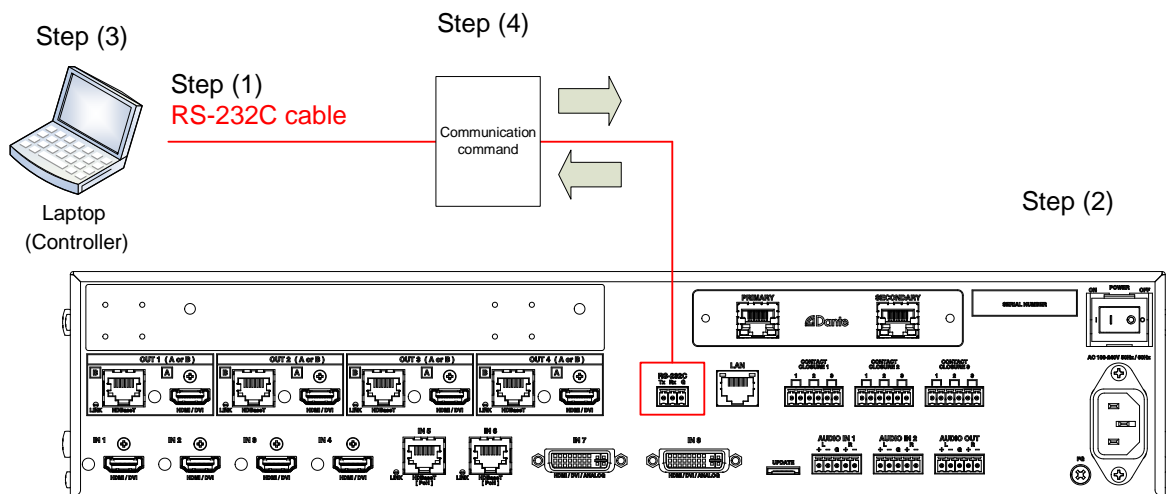

[Fig. 2.2] Setting RS-232C communication (Example: MSD-6204 with Dante)

■ Operation example of RS-232C communication

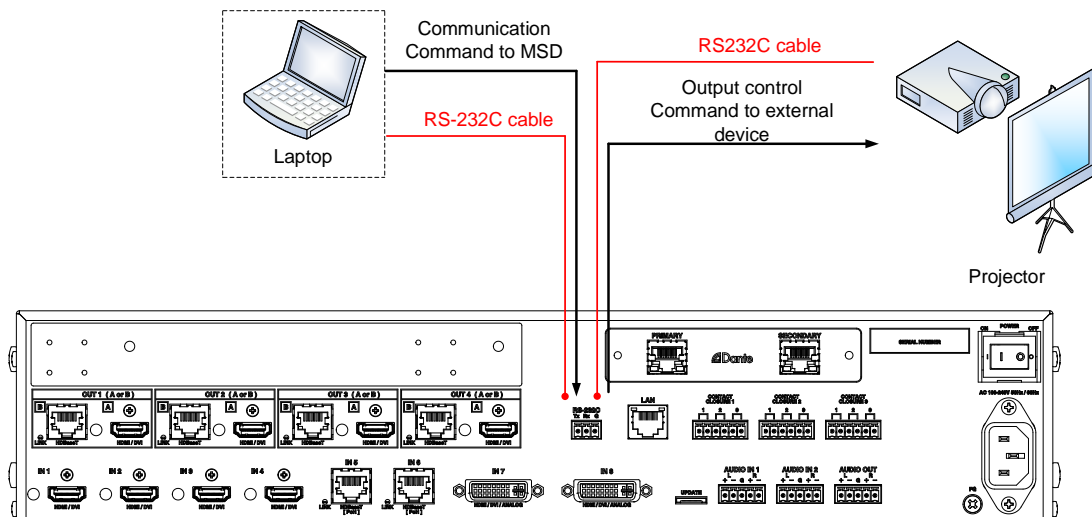

[Fig. 2.3] RS-232C communication (Example: MSD-6204 with Dante)

2.2 LAN communication

2.2.1 LAN connector specification

It supports Auto MDI/MDI-X, which distinguishes/switches straight and cross cables automatically.

Pin assignments of LAN connector:

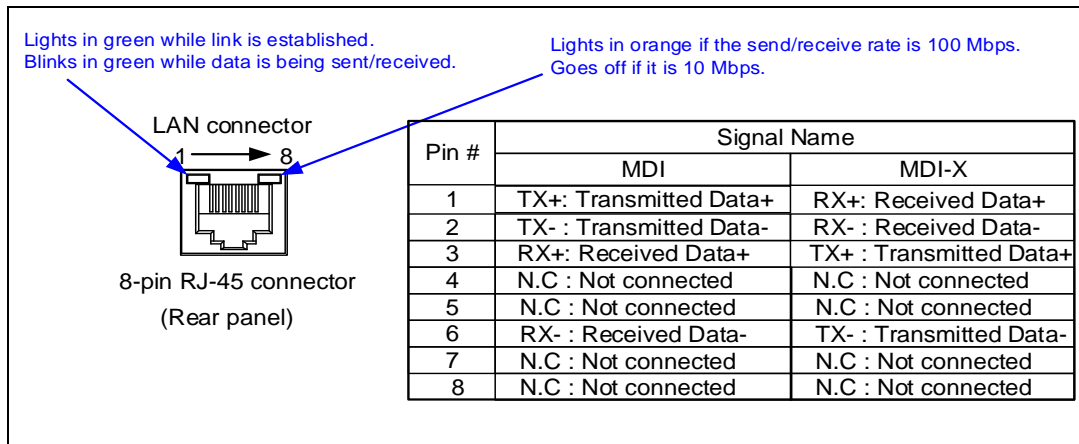

[Fig. 2.4] LAN connector

2.2.2 LAN communication specification

[Table 2.2] Specification of LAN communication

| | |
|-----------------|---|
| Physical layer | 10Base-T (IEEE802.3i) / 100Base-TX (IEEE802.3u) |
| Network layer | ARP, IP, ICMP |
| Transport layer | TCP |
| | Port used for command control: 23, 1100, 6000 to 6999 Port used for WEB browser control (HTTP): 80, 5000 to 5999 |

Note: Up to 8 connections can be used simultaneously.

2.2.3 Setting up LAN communication

- (1) Connect the MSD and the control device via a LAN cable.
- (2) Set up LAN communication as follows:
 - Set IP address and subnet mask
 - Operation mode of LAN communication: "RECEIVER"
 - TCP port number: 23, 1100, 6000 to 6999

【Reference: User Guide】

- (3) Establish the connection from the control device to the IP address and TCP port that are set to the MSD in step (2) above.
- (4) Send a communication command from the control device to the MSD in order to check the control status of the MSD.

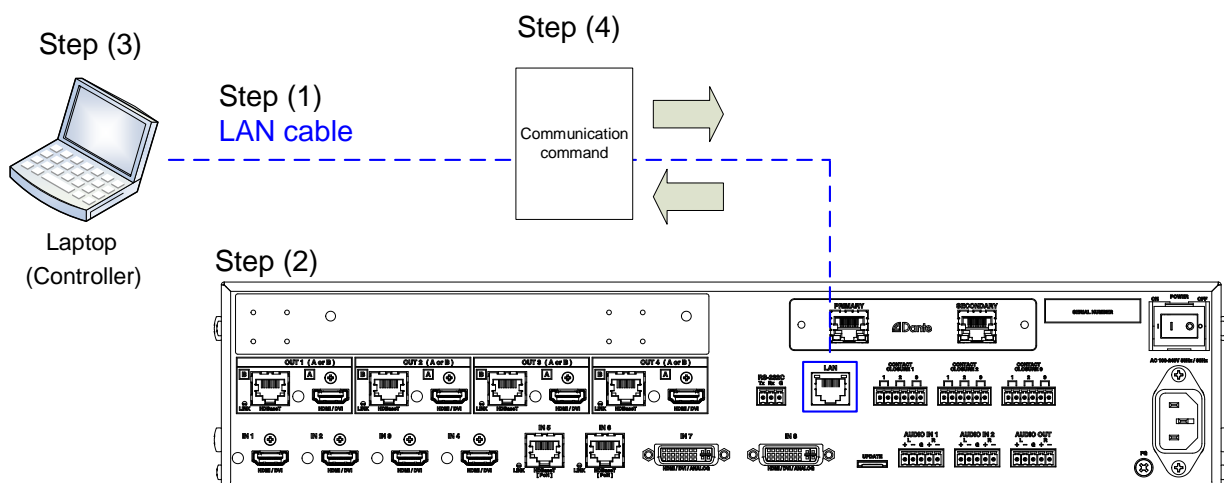

[Fig. 2.5] Setting LAN communication (Example: MSD-6204 with Dante)

■ Operation example of LAN communication

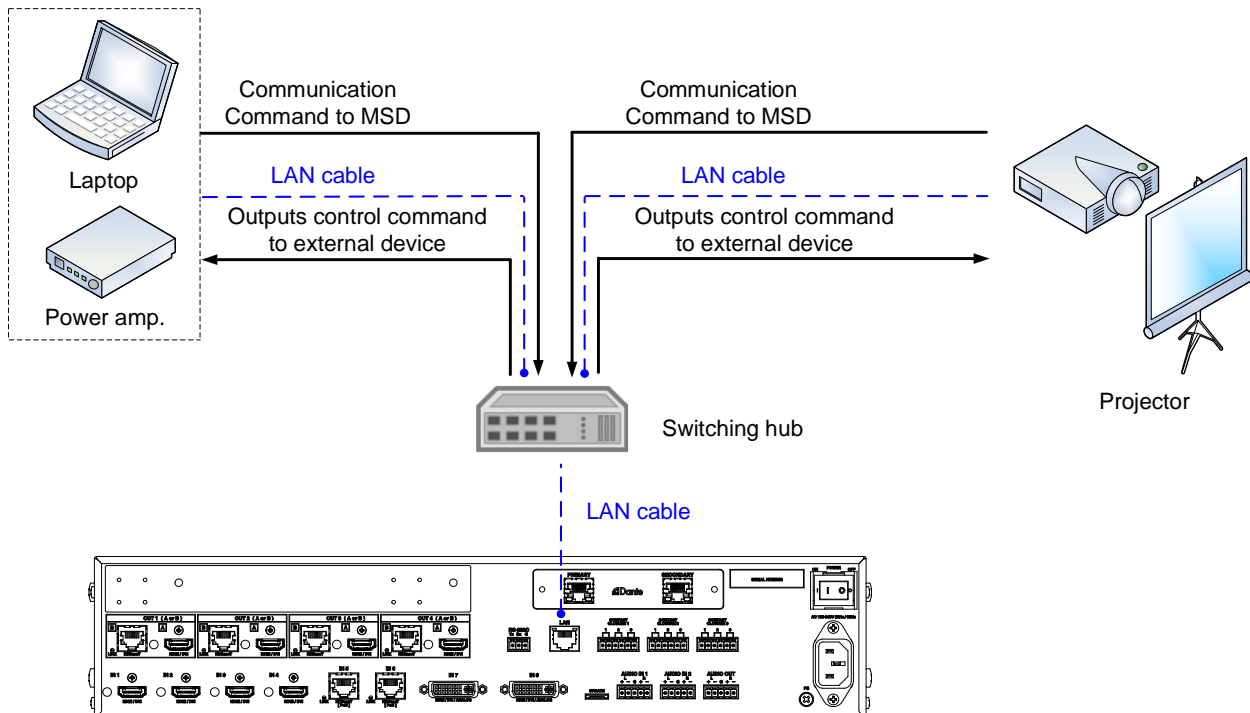

[Fig. 2.6] Example of LAN communication (Example: MSD-6204 with Dante)

2.2.4 The number of TCP-IP connections

The MSD series can connect up to eight connections (eight ports) simultaneously. If the MSD is controlled from nine or more PCs, they may not be connected to the MSD normally, since the number of connections that can be used is limited.

If you use nine connections or more, execute TCP-IP connection/close every time the communication command is sent or received from the software of user's side. By doing so, MSD's ports are occupied or released so that nine or more connections can be connected logically.

[Table 2.3] Increasing connections

| Your PC software | | MSD |
|---------------------|---|--------------------------|
| TCP-IP connection | → | (Occupied by 1 port) |
| Send command (@xxx) | → | |
| | ← | Send back command (@xxx) |
| TCP-IP close | → | (Release 1 port) |

Note:

If any command is not sent from the PC side to the MSD for 30 seconds, the MSD disconnects the connection to avoid the limitation problem on the number of connections. As a result, connection needs to be established again from the PC side after the current connection of the PC is disconnected.

(Since the number of ports in the MDS is eight, ports are occupied permanently if the PC is turned off while connections are valid. To prevent this, the MSD disconnects connections if no communication command is sent from the PC side.)

3 Command

3.1 Command outline

A command consists of “@” (“40” in hexadecimal), 3 one-byte alphabetical characters (upper and lower cases), and parameters (one-byte numbers”). For some commands, several parameters can be specified or no parameter is required. Processing is executed by sending a delimiter at the end of the command.

Example: @SPM,2 ↵

“,” (a comma, “2C” in hexadecimal) is indicated between a command and parameter and between two parameters.

■ If there is an error:

An error command is returned if an undefined command or wrong parameter is included.

Example: @SOT,1 ↵
 @ERR,1 ↵

■ Using as HELP

If only delimiter is sent, command list as the help command is returned.

Example: ↵
 ----- HELP (1/14) ----- ↵
 (CHANNEL SELECT Command) ↵
 @GSW / @SSW : Get/Set Input Channel ↵
 @GSV / @SSV : Get/Set Video Input Channel ↵
 @GSA / @SSA : Get/Set Audio Input Channel ↵

3.2 Command list

■ Error status

| Command | Function | Page |
|---------|--------------|------|
| @ERR | Error status | 18 |

■ Power status

| Command | Function | Page |
|-------------|----------------|------|
| @GPS / @SPS | Standby button | 19 |

■ Input channels

| Command | Function | Page |
|-------------|--|------|
| @GSW / @SSW | Switching video and audio channel simultaneously | 19 |
| @GSV / @SSV | Switching video channel | 20 |
| @GSA / @SSA | Switching audio channel | 20 |

■ Position, size, and masking

| Command | Function | Page |
|-------------|-----------------------------|------|
| @GOT / @SOT | Output resolution | 21 |
| @GTD | Actual output resolution | 22 |
| @GUM / @SUM | Aspect ratio of sink device | 23 |
| @GAP / @SAP | Aspect ratio | 23 |
| @GAR / @SAR | Aspect ratio restoration | 24 |
| @GOV / @SOV | Overscan | 24 |
| @GNP / @SNP | Input position | 25 |
| @GNS / @SNS | Input size | 26 |
| @GNM / @SNM | Input masking | 27 |
| @IAS | Input automatic sizing | 27 |
| @GOP / @SOP | Output position | 28 |
| @GOS / @SOS | Output size | 29 |
| @GOM / @SOM | Output masking | 30 |
| @OAS | Output automatic sizing | 30 |
| @GBC / @SBC | Background color | 31 |
| @GTP / @STP | Test pattern | 32 |

■ Video processing

| Command | Function | Page |
|-------------|-------------------------|------|
| @GOR / @SOR | Video processing mode | 33 |
| @GPR / @SPR | Window display priority | 33 |
| @GOI / @SOI | Flip horizontal | 34 |
| @GWV / @SWV | Hiding window | 34 |

■ Image quality

| Command | Function | Page |
|-------------|----------------------|------|
| @GFL / @SFL | Sharpness | 35 |
| @GBR / @SBR | Input brightness | 35 |
| @GCO / @SCO | Input contrast | 36 |
| @GHU / @SHU | Hue | 36 |
| @GST / @SST | Saturation | 37 |
| @GSU / @SSU | Black level | 37 |
| @IDC | Input default color | 38 |
| @GOB / @SOB | Output brightness | 38 |
| @GOC / @SOC | Output contrast | 39 |
| @GGM / @SGM | Output gamma | 39 |
| @ODC | Output default color | 40 |

■ Input settings

| Command | Function | Page |
|-------------|---|------|
| @GDT / @SDT | No-signal-input monitoring | 40 |
| @GHE / @SHE | HDCP input enabled/disabled | 41 |
| @GAI / @SAI | Analog input type | 41 |
| @GID / @SID | Automatic detection of input video interruption | 42 |
| @GIN / @SIN | Signal selection of DVI input connector | 42 |
| @GIA / @SIA | HDBaseT input long reach mode | 43 |
| @GFX / @SFX | Fixing settings for input signal | 44 |

■ Input timing

| Command | Function | Page |
|-------------|---|------|
| @AIS / @AIT | Automatic measurement | 45 |
| @GHT / @SHT | The total number of horizontal dots | 46 |
| @GHS / @SHS | Horizontal start position | 47 |
| @GHD / @SHD | Horizontal display period | 47 |
| @GVS / @SVS | Vertical start position | 48 |
| @GVD / @SVD | Vertical display period | 48 |
| @GIS / @SIS | Automatic measurement of start position | 49 |
| @GSM / @SSM | Automatic measurement when unregistered signal is input | 49 |
| @RTT | Loading device data | 50 |
| @STT | Registering device data | 50 |
| @GTK / @STK | Tracking | 51 |

■ Output settings

| Command | Function | Page |
|-------------|--|------|
| @GEQ / @SEQ | Output equalizer | 52 |
| @GDM / @SDM | Output mode | 52 |
| @GUY / @SUY | Synchronous signal output when no video signal is input | 53 |
| @GBO / @SBO | Output video when no video signal is not input | 53 |
| @GFF / @SFF | Video switching effect | 54 |
| @GFT / @SFT | Video switching speed | 54 |
| @GWC / @SWC | Wipe color | 55 |
| @GVO / @SVO | HDMI / HDBaseT output | 56 |
| @GEN / @SEN | HDCP output | 57 |
| @GHR / @SHR | The number of HDCP retries | 57 |
| @GDC / @SDC | Deep Color | 58 |
| @GCE / @SCE | CEC connection | 58 |
| @HAU | HDCP re-encryption | 59 |
| @GAU / @SAU | Priority of input channel automatic switching (OFF to ON) | 59 |
| @GOF / @SOF | Priority of input channel automatic switching (ON to OFF) | 60 |
| @GMT / @SMT | Masking time after automatic switching of input channel | 60 |
| @GAD / @SAD | Channel switching mode for input channel automatic switching | 61 |
| @GOA / @SOA | HDBaseT output long reach mode | 61 |

■ Audio

| Command | Function | Page |
|-------------|--------------------------------------|------|
| @GSL / @SSL | Audio output level | 62 |
| @SOL | Relative value of audio output level | 62 |
| @GOL | Limit status of audio output level | 63 |
| @GAM / @SAM | Audio output mute | 63 |
| @GAS / @SAS | Selecting audio input | 64 |
| @GSO / @SSO | Audio input level | 65 |
| @SIL | Relative value of audio input level | 65 |
| @GIL | Limit status of audio input level | 65 |
| @GLO / @SLO | Output lip sync | 66 |
| @GLY / @SLY | Input lip sync | 66 |
| @GSF / @SSF | Sampling frequency | 67 |
| @GFD | Actual sampling frequency | 67 |
| @GCS / @SCS | Analog audio output | 68 |
| @GMD / @SMD | Multi channel audio output | 68 |
| @GAT / @SAT | Test tone | 69 |

■ EDID

| Command | Function | Page |
|-------------|---------------------------------|------|
| @GED / @SED | EDID | 70 |
| @GVF / @SVF | Input resolution for PC | 71 |
| @GHF / @SHF | Input resolution for AV devices | 72 |
| @GDI / @SDI | Deep Color input | 73 |
| @GAF / @SAF | Audio format | 74 |
| @GSP / @SSP | The number of speakers (cont'd) | 76 |
| @RME | Copying EDID | 76 |

■ RS-232C communication

| Command | Function | Page |
|-------------|-----------------------------------|------|
| @GCT / @SCT | RS-232C communication | 77 |
| @GCF / @SCF | RS-232C communication mode | 78 |
| @GCI / @SCI | RS-232C transmission | 79 |
| @GCQ / @SCQ | RS-232C HDBaseT sending channel | 80 |
| @GCR / @SCR | RS-232C HDBaseT receiving channel | 80 |

■ LAN communication

| Command | Function | Page |
|-------------|------------------------|------|
| @GIP / @SIP | IP address | 81 |
| @GSB / @SSB | Subnet mask | 82 |
| @GGW / @SGW | Gateway address | 82 |
| @GLF / @SLF | LAN communication mode | 83 |
| @GLP / @SLP | TCP port number | 84 |
| @GMC | MAC address | 84 |

■ Control commands

| Command | Function | Page |
|-------------|---|------|
| @EXC | Executing control commands | 85 |
| @GDS / @SDS | Power button of sink device | 85 |
| @GEC / @SEC | Control command (Communication command) | 86 |
| @GEC / @SEC | Control command (Displaying received data) | 88 |
| @GEC / @SEC | Control command (contact closure) | 90 |
| @GEC / @SEC | Control command (CEC) | 91 |
| @GRC / @SRC | Response command | 92 |
| @GCC / @SCC | Control command link | 93 |
| @GTG / @STG | Toggle operation | 95 |
| @GUP / @SUP | Plane to be executed when powered ON | 95 |
| @GIT / @SIT | Ineffective time during control command execution | 96 |
| @DEC | Initializing registered command and link | 96 |
| @GTL / @STL | Lighting condition of execution button | 97 |
| @GTF / @STF | Blinking time of sink device power switch | 98 |

■ Preset memory

| Command | Function | Page |
|-------------|--|------|
| @RCM | Loading crosspoint memory | 99 |
| @SCM / @SEM | Saving channels to crosspoint memory | 99 |
| @GCM / @ECM | Editing crosspoint memory | 100 |
| @RCV | Loading crosspoint memory (setting video channel) | 100 |
| @SCV / @SEV | Saving crosspoint memory (Setting video channel) | 101 |
| @GCV / @ECV | Editing crosspoint memory (Setting video channel) | 101 |
| @RCA | Loading audio channel setting from crosspoint memory | 102 |
| @SCA / @SEA | Saving crosspoint memory (Setting audio channel) | 102 |
| @GCA / @ECA | Editing crosspoint memory (Setting audio channel) | 103 |
| @RPM | Loading all settings | 103 |
| @SPM | Saving all settings | 104 |
| @SCP | Copying output setting | 104 |
| @GMU / @SMU | Startup settings | 105 |

■ Bitmap

| Command | Function | Page |
|-------------|-------------------------|------|
| @GBM / @SBM | Outputting bitmap image | 105 |
| @GBB / @SBB | Background color | 106 |
| @GBT / @SBT | Aspect ratio | 107 |
| @GZP / @SZP | Display position | 108 |
| @GBA / @SBA | Assigning input channel | 109 |
| @GPB / @SPB | Startup bitmap | 109 |
| @GBD / @SBD | Dividing memory area | 110 |
| @GBV | Memory area status | 110 |
| @GFZ / @SFZ | Freeze | 111 |
| @CAP | Capturing input image | 111 |



■ Other settings

| Command | Function | Page |
|-------------|--------------------------------|------|
| @GLS / @SLS | Operation lock | 112 |
| @GLM / @SLM | Setting operation to be locked | 112 |
| @GBZ / @SBZ | Buzzer | 113 |
| @GHP / @SHP | Power supply of HDBaseT input | 113 |
| @GSS | I/O status | 114 |
| @GES | Monitor's EDID | 118 |
| @GIV | Version | 118 |

3.3 Detailed descriptions

Command formats for MSD-6204 are shown in this section. For other models, use each appropriate command formats according to the number of outputs.

3.3.1 Error status

| @ERR | | Error status |
|-----------------|-------------|---|
| Description | | Response in case the command is not executed. |
| Response | | @ERR, error  |
| Parameter | | error: Error status 1 = Erroneous parameter format or value 2 = Undefined command or wrong format 3 = Currently cannot be used. 4 = Not used. 5 = The command could not be executed, because the control command was not registered. 6 = The command could not be processed since another command was being executed. 7 = Automatic measurement of input timing failed. 8 = Loading EDID from the sink device failed. 9 = Not used. 10 = The control command was stopped according to the stop condition. 11 = The control command was stopped since the number of retries exceeded the set value of "RETRY". 12 = The control command of PJLink was stopped since the password did not match. 13 = The image could not be captured since the image size to be captured exceeded the reserved memory size. 14 = Capturing input image failed. |
| Getting example | Command | Command @IOS  |
| | Response | Response @ERR,2  |
| | Description | @IOS is sent. Command format error. |
| Remarks | | — |

3.3.2 Power status

| @GPS / @SPS | | Standby button |
|-----------------|-------------|---|
| Getting | Command | @GPS ↵ |
| | Response | @GPS, onoff ↵ |
| Setting | Command | @SPS, onoff ↵ |
| | Response | @SPS, onoff ↵ |
| Parameter | | onoff: Standby button 0 = OFF (Standby), 1 = ON (Power on) |
| Getting example | Command | @GPS ↵ |
| | Response | @GPS,1 ↵ |
| | Description | Getting the standby button status. It is powered on. |
| Setting example | Command | @SPS,1 ↵ |
| | Response | @SPS,1 ↵ |
| | Description | Setting the standby button to ON (powered on). |
| Remarks | | — |

3.3.3 Input channels





| @GSW / @SSW | | Switching video and audio channel simultaneously |
|-----------------|-------------|---|
| Getting | Command | @GSW ↵ |
| | Response | @GSW, video_1, audio_1, video_2, audio_2, ..., video_4, audio_4 ↵ |
| Setting | Command | @SSW, input_1, output_1 (, input_2, output_2···) ↵ |
| | Response | @SSW, input_1, output_1 (, input_2, output_2···) ↵ |
| Parameter | | video_1-4 : Video input channel audio_1-4 : Audio input channel input_1-4 : Video and audio input channel 0 = OFF [Default], 1 = IN1 to 8 = IN8 output_1-4: Video and audio output channel 0 = All outputs, 1 = OUT1 to 4 = OUT4 |
| Getting example | Command | @GSW ↵ |
| | Response | @GSW,2,2,2,2,0,0,0,0 ↵ |
| | Description | Getting the video and audio input channels that are assigned to output channels. OUT1 and OUT2: IN2, OUT3 and OUT4: OFF |
| Setting example | Command | @SSW,1,1 ↵ |
| | Response | @SSW,1,1 ↵ |
| | Description | Setting IN1 video and audio to be output to OUT1. |
| Remarks | | — |

| @GSV / @SSV | | Switching video channel |
|--------------------|-------------|---|
| Getting | Command | @GSV |
| | Response | @GSV, input_1, input_2, input_3, input_4 |
| Setting | Command | @SSV, input_1, output_1 (, input_2, output_2···) |
| | Response | @SSV, input_1, output_1 (, input_2, output_2···) |
| Parameter | | input_1-4: Video input channel 0 = OFF [Default], 1 = IN1 to 8 = IN8 |
| | | output_1-4: Video output channel 0 = All outputs, 1 = OUT1 to 4 = OUT4 |
| Getting example | Command | @GSV |
| | Response | @GSV,1,1,2,2 |
| | Description | Getting the video I/O channel statuses. OUT1 and OUT2: IN1, OUT3 and OUT4: IN2 |
| Setting example | Command | @SSV,1,1 |
| | Response | @SSV,1,1 |
| | Description | Setting IN1 video to be output to OUT1. |
| Remarks | | — |

| @GSA / @SSA | | Switching audio channel |
|--------------------|-------------|---|
| Getting | Command | @GSA |
| | Response | @GSA, input_1, input_2, input_3, input_4 |
| Setting | Command | @SSA, input_1, output_1 (, input_2, output_2···) |
| | Response | @SSA, input_1, output_1 (, input_2, output_2···) |
| Parameter | | input_1-4: Audio input channel 0 = OFF [Default], 1 = IN1 to 8 = IN8 |
| | | output_1-4: Audio output channel 0 = All outputs, 1 = OUT1 to 4 = OUT4 |
| Getting example | Command | @GSA |
| | Response | @GSA,1,1,2,2 |
| | Description | Getting the audio I/O channel status. OUT1 and OUT2: IN1, OUT3 and OUT4: IN2 |
| Setting example | Command | @SSA,1,1 |
| | Response | @SSA,1,1 |
| | Description | Setting IN1 audio to be output to OUT1. |
| Remarks | | — |

3.3.4 Position, size, and masking

| @GOT / @SOT | | Output resolution |
|-----------------|-------------|---|
| Getting | Command | @GOT [↵] |
| | Response | @GOT, resolution_1, resolution_2, resolution_3, resolution_4 [↵] |
| Setting | Command | @SOT, ch_1, resolution_1 (, ch_2, resolution_2···) [↵] |
| | Response | @SOT, ch_1, resolution_1 (, ch_2, resolution_2···) [↵] |
| Parameter | | resolution_1-4: Setting value of output resolution 0 = AUTO [Default], 4 = WXGA@60 (1280x768), 6 = Quad-VGA@60 (1280x960), 8 = WXGA@60 (1360x768), 10 = SXGA+@60 (1400x1050), 12 = WXGA++@60 (1600x900), 14 = WSXGA+@60 (1680x1050), 16 = WUXGA@60 (1920x1200), 24 = 720p@50 (1280x720), 26 = 720p@60 (1280x720), 28 = 1080i@59.94 (1920x1080), 30 = 1080p@50 (1920x1080), 32 = 1080p@60 (1920x1080), 41 = 2160p@25 (3840x2160), 45 = 2160p@24 (4096x2160), 47 = 2160p@30 (4096x2160) 3 = XGA@60 (1024x768), 5 = WXGA@60 (1280x800), 7 = SXGA@60 (1280x1024), 9 = WXGA@60 (1366x768), 11 = WXGA+@60 (1440x900), 13 = UXGA@60 (1600x1200), 15 = VESAHD@60 (1920x1080), 17 = QWXGA@60 (2048x1152), 25 = 720p@59.94 (1280x720), 27 = 1080i@50 (1920x1080), 29 = 1080i@60 (1920x1080), 31 = 1080p@59.94(1920x1080), 40 = 2160p@24 (3840x2160), 42 = 2160p@30 (3840x2160), 46 = 2160p@25 (4096x2160), |
| | | ch_1-4: Output channel 0 = All outputs, 1 = OUT1 to 4 = OUT4 |
| Getting example | Command | @GOT [↵] |
| | Response | @GOT,7,7,31,31[↵] |
| | Description | Getting the set output resolution. OUT1 and OUT2: SXGA, OUT3 and OUT4: 1080p 59.94 Hz |
| Setting example | Command | @SOT,1,31 [↵] |
| | Response | @SOT,1,31 [↵] |
| | Description | Setting output resolution of OUT1 to 1080p 59.94 Hz. |
| Remarks | | — |

| @GTD | | Actual output resolution |
|-----------------|-------------|---|
| Getting | Command | @GTD  |
| | Response | @GTD, resolution_1, resolution_2, resolution_3, resolution_4  |
| Parameter | | resolution_1-4: Actual output resolution 1 = VGA@60 (640x480), 2 = SVGA@60 (800x600), 3 = XGA@60 (1024x768), 4 = WXGA@60 (1280x768), 5 = WXGA@60 (1280x800), 6 = Quad-VGA@60 (1280x960), 7 = SXGA@60 (1280x1024), 8 = WXGA@60 (1360x768), 9 = WXGA@60 (1366x768), 10 = SXGA+@60 (1400x1050), 11 = WXGA+@60 (1440x900), 12 = WXGA++@60 (1600x900), 13 = UXGA@60 (1600x1200), 14 = WSXGA+@60 (1680x1050), 15 = VESAHD@60 (1920x1080), 16 = WUXGA@60 (1920x1200), 17 = QWXGA@60 (2048x1152), 21 = 480p@59.94 (720x480), 23 = 576p@50 (720x576), 24 = 720p@50 (1280x720), 25 = 720p@59.94 (1280x720), 26 = 720p@60 (1280x720), 27 = 1080i@50 (1920x1080), 28 = 1080i@59.94 (1920x1080), 29 = 1080i@60 (1920x1080), 30 = 1080p@50 (1920x1080), 31 = 1080p@59.94 (1920x1080), 32 = 1080p@60 (1920x1080), 40 = 2160p@24 (3840x2160), 41 = 2160p@25 (3840x2160), 42 = 2160p@30 (3840x2160), 45 = 2160p@24 (4096x2160), 46 = 2160p@25 (4096x2160), 47 = 2160p@30 (4096x2160) |
| Getting example | Command | @GTD  |
| | Response | @GTD,31,31,26,26  |
| | Description | Getting the actual output resolution. OUT1 and OUT2: 1080p 59.94 Hz, OUT3 and OUT4: 720p 60 Hz |
| Remarks | | If “@GOT / @SOT Output resolution” is set to “AUTO”, the actual output resolution is returned. If “@GOT / @SOT Output resolution” is set to the value other than “AUTO”, the set output resolution is returned. |









| @GUM / @SUM | | Aspect ratio of sink device |
|--------------------|-------------|---|
| Getting | Command | @GUM |
| | Response | @GUM, aspect_1, aspect_2, aspect_3, aspect_4 |
| Setting | Command | @SUM, ch_1, aspect_1 (, ch_2, aspect_2···) |
| | Response | @SUM, ch_1, aspect_1 (, ch_2, aspect_2···) |
| Parameter | | aspect_1-4: Aspect ratio of sink device 0 = RESOLUTION [Default], 1 = 4:3, 2 = 5:4, 3 = 5:3, 4 = 16:9, 5 = 16:10, 6 = 256:135 ch_1-4: Output channel 0 = All outputs, 1 = OUT1 to 4 = OUT4 |
| Getting example | Command | @GUM |
| | Response | @GUM,4,4,5,5 |
| | Description | Getting the set aspect ratio of the sink device. OUT1 and OUT2: 16:9, OUT3 and OUT4: 16:10 |
| Setting example | Command | @SUM,1,4 |
| | Response | @SUM,1,4 |
| | Description | Setting OUT1 to 16:9. |
| Remarks | | — |

| @GAP / @SAP | | Aspect ratio |
|--------------------|-------------|---|
| Getting | Command | @GAP |
| | Response | @GAP, aspect_1, aspect_2, aspect_3, ···, aspect_8 |
| Setting | Command | @SAP, ch_1, aspect_1 (, ch_2, aspect_2···) |
| | Response | @SAP, ch_1, aspect_1 (, ch_2, aspect_2···) |
| Parameter | | aspect_1-8: Aspect ratio of input signal 0 = AUTO-1 [Default], 1 = AUTO-2, 2 = 4:3, 3 = 16:9, 4 = 14:9, 5 = 16:9 LETTER BOX, 6 = 14:9 LETTER BOX, 7 = 4:3 SIDE PANEL, 8 = 14:9 SIDE PANEL, 9 = FULL, 10 = THROUGH ch_1-8: Input channel 0 = All inputs, 1 = IN1 to 8 = IN8 |
| Getting example | Command | @GAP |
| | Response | @GAP,0,0,2,0,0,0,0,0 |
| | Description | Getting the set aspect ratio. IN3: 4:3, Other inputs: AUTO-1 |
| Setting example | Command | @SAP,7,2 |
| | Response | @SAP,7,2 |
| | Description | Setting IN7 to 4:3. |
| Remarks | | — |

| @GAR / @SAR | | Aspect ratio restoration |
|--------------------|-------------|---|
| Getting | Command | @GAR |
| | Response | @GAR, mode_1, mode_2, mode_3, ..., mode_8 |
| Setting | Command | @SAR, ch_1, mode_1 (, ch_2, mode_2····) |
| | Response | @SAR, ch_1, mode_1 (, ch_2, mode_2····) |
| Parameter | | mode_1-8: Aspect ratio restoration 0 = Letter box/Side panel [Default], 1 = Side cut/Top bottom cut |
| | | ch_1-8: Input channel 0 = All inputs, 1 = IN1 to 8 = IN8 |
| Getting example | Command | @GAR |
| | Response | @GAR,0,0,1,0,0,0,0 |
| | Description | Getting the set aspect ratio restoration processing. IN3: Side cut/Top bottom cut, Other inputs: Letter box/Side panel |
| Setting example | Command | @SAR,5,1 |
| | Response | @SAR,5,1 |
| | Description | Setting IN5 to Side cut/Top bottom cut. |
| Remarks | | — |

| @GOV / @SOV | | Overscan |
|--------------------|-------------|---|
| Getting | Command | @GOV |
| | Response | @GOV, overscan_1, overscan_2, overscan_3, ..., overscan_8 |
| Setting | Command | @SOV, ch_1, overscan_1 (, ch_2, overscan_2····) |
| | Response | @SOV, ch_1, overscan_1 (, ch_2, overscan_2····) |
| Parameter | | overscan_1-8: Overscan 100 to 115 [Default] NTSC / PAL / SDTV: 105, HDTV / PC: 100 |
| | | ch_1-8: Input channel 0 = All inputs, 1 = IN1 to 8 = IN8 |
| Getting example | Command | @GOV |
| | Response | @GOV,100,100,105,100,100,100,100 |
| | Description | Getting the set overscan. IN3: 105 %, Other inputs: 100 % |
| Setting example | Command | @SOV,7,105 |
| | Response | @SOV,7,105 |
| | Description | Setting IN7 to 105%. |
| Remarks | | — |

| @GNP / @SNP | | Input position |
|-----------------|-------------|--|
| Getting | Command | @GNP ↵ |
| | Response | @GNP, h_position_1, v_position_1, h_position_2, v_position_2···, h_position_8, v_position_8 ↵ |
| Setting | Command | @SNP, ch_1, h_position_1, v_position_1 (, ch_2, h_position_2, v_position_2···) ↵ |
| | Response | @SNP, ch_1, h_position_1, v_position_1 (, ch_2, h_position_2, v_position_2···) ↵ |
| Parameter | | h_position_1-8: Horizontal input position -Horizontal input size to +Horizontal output resolution [Default] 0 |
| | | v_position_1-8: Vertical input position -Vertical input size to +Vertical output resolution [Default] 0 |
| | | ch_1-8: Input channel 0 = All inputs, 1 = IN1 to 8 = IN8 |
| Getting example | Command | @GNP ↵ |
| | Response | @GNP,-50,20,0,0,0,0,0,0,0,0,0,0,0,0,0,0 ↵ |
| | Description | Getting the set input position. N1: horizontal input display is -50, vertical input display is +20. Other inputs: horizontal and vertical input positions are 0. |
| Setting example | Command | @SNP,1,-50,20 ↵ |
| | Response | @SNP,1,-50,20 ↵ |
| | Description | Setting IN1 horizontal and vertical input positions are to -50 and +20, respectively. |
| Remarks | | If resolutions differ depending on output, the OUT1 output resolution will be the standard. |

| @GNS / @SNS | | Input size |
|-----------------|-------------|--|
| Getting | Command | @GNS  |
| | Response | @GNS, h_size_1, v_size_1, h_size_2, v_size_2... , h_size_8, v_size_8  |
| Setting | Command | @SNS, ch_1, h_size_1, v_size_1 (, ch_2, h_size_2, v_size_2...)  |
| | Response | @SNS, ch_1, h_size_1, v_size_1 (, ch_2, h_size_2, v_size_2...)  |
| Parameter | | h_size_1-8: Horizontal input size Horizontal output resolution ÷4 to Horizontal output resolution ×4 [Default] Horizontal output resolution |
| | | v_size_1-8: Vertical input size Vertical output resolution ÷4 to Vertical output resolution ×4 [Default] Vertical output resolution |
| | | ch_1-8: Input channel 0 = All inputs, 1 = IN1 to 8 = IN8 |
| Getting example | Command | @GNS  |
| | Response | @GNS,1925,1084,1920,1080,1920,1080,1920,1080,1920,1080,1920,1080,1920,1080  |
| | Description | Getting the set input size. Horizontal and vertical display sizes of IN1 are 1925 and 1084, respectively. Other inputs: 1920 and 1080, respectively. |
| Setting example | Command | @SNS,1,1925,1084  |
| | Response | @SNS,1,1925,1084  |
| | Description | Setting IN1 horizontal and vertical input size are 1925 and 1084, respectively. |
| Remarks | | If resolutions differ depending on outputs, the resolution of OUT1 will be the standard. |

| @GNM / @SNM | | Input masking |
|--------------------|-------------|--|
| Getting | Command | @GNM, ch ↵ |
| | Response | @GNM, ch, left, right, top, bottom ↵ |
| Setting | Command | @SNM, ch, left, right, top, bottom ↵ |
| | Response | @SNM, ch, left, right, top, bottom ↵ |
| Parameter | | ch: Input channel 1 = IN1 to 8 = IN8 left: Left side masking Horizontal input position to right side masking [Default] 0 right: Right side masking Left side masking to horizontal input position + horizontal input size [Default] Horizontal input size top: Top side masking Vertical input position to bottom side masking [Default] 0 bottom: Bottom side masking Top side masking to vertical input position +vertical input size [Default] Vertical input size |
| Getting example | Command | @GNM,1 ↵ |
| | Response | @GNM,1,0,1920,0,1080 ↵ |
| | Description | Getting the set IN1 input masking. Left: 0, right: 1920, top: 0, bottom: 1080 |
| Setting example | Command | @SNM,1,0,1920,0,1080 ↵ |
| | Response | @SNM,1,0,1920,0,1080 ↵ |
| | Description | Setting IN1 input masking to 0 for left, 1920 for right, 0 for top, 1080 for bottom. |
| Remarks | | — |

| @IAS | | Input automatic sizing |
|-----------------|-------------|---|
| Setting | Command | @IAS, ch_1 (, ch_2···) ↵ |
| | Response | @IAS, ch_1 (, ch_2···) ↵ |
| Parameter | | ch_1-8: Input channel 0 = All inputs, 1 = IN1 to 8 = IN8 |
| Setting example | Command | @IAS,1 ↵ |
| | Response | @IAS,1 ↵ |
| | Description | Initializing the following settings in order to display images input from IN1 on the full screen: @GAP / @SAP Aspect ratio @GOV / @SOV Overscan @GNP / @SNP Input position @GNS / @SNS Input size @GNM / @SNM Input masking |
| Remarks | | — |

| @GOP / @SOP | | Output position |
|--------------------|-------------|--|
| Getting | Command | @GOP ↵ |
| | Response | @GOP, h_position_1, v_position_1, h_position_2, v_position_2, h_position_3, v_position_3, h_position_4, v_position_4 ↵ |
| Setting | Command | @SOP, ch_1, h_position_1, v_position_1 (, ch_2, h_position_2, v_position_2···) ↵ |
| | Response | @SOP, ch_1, h_position_1, v_position_1 (, ch_2, h_position_2, v_position_2···) ↵ |
| Parameter | | h_position_1-4: Horizontal output position -Horizontal output size to +Horizontal output resolution [Default] 0 |
| | | v_position_1-4: Vertical output position -Vertical output size to +Vertical output resolution [Default] 0 |
| | | ch_1-4: Output channel 0 = All outputs, 1 = OUT1 to 4 = OUT4 |
| Getting example | Command | @GOP ↵ |
| | Response | @GOP,5,20,5,20,0,0,0,0 ↵ |
| | Description | Getting the set output position. OUT1 and OUT2: horizontal position is +5, vertical position is +20. OUT3 and OUT4: horizontal and vertical positions: 0 |
| Setting example | Command | @SOP,1,5,20 ↵ |
| | Response | @SOP,1,5,20 ↵ |
| | Description | Setting OUT1 horizontal and vertical positions to +5 and +20, respectively. |
| Remarks | | — |

| @GOS / @SOS | | Output size |
|--------------------|-------------|---|
| Getting | Command | @GOS ↵ |
| | Response | @GOS, h_size_1, v_size_1, h_size_2, v_size_2, h_size_3, v_size_3, h_size_4, v_size_4 ↵ |
| Setting | Command | @SOS, ch_1, h_size_1, v_size_1 (, ch_2, h_size_2, v_size_2···) ↵ |
| | Response | @SOS, ch_1, h_size_1, v_size_1 (, ch_2, h_size_2, v_size_2···) ↵ |
| Parameter | | <p>h_size_1-4: Horizontal output size Horizontal output resolution÷4 to Horizontal output resolution×4 [Default] Horizontal output resolution</p> <p>v_size_1-4: Vertical output size Vertical output resolution÷4 to Vertical output resolution×4 [Default] Vertical output resolution</p> <p>ch_1-4: Output channel 0 = All outputs, 1 = OUT1 to 4 = OUT4</p> |
| Getting example | Command | @GOS ↵ |
| | Response | @GOS,1920,1035,1920,1035,1920,1080,1920,1080 ↵ |
| | Description | <p>Getting the set output size.</p> <p>OUT1 and OUT2: horizontal output size is 1920, vertical output size is 1035, respectively.</p> <p>OUT3 and OUT4: horizontal output size is 1920, vertical output size is 1080, respectively.</p> |
| Setting example | Command | @SOS,1,1920,1080 ↵ |
| | Response | @SOS,1,1920,1080 ↵ |
| | Description | Setting OUT1 horizontal and vertical output sizes to 1920 and 1080, respectively. |
| Remarks | | — |

| @GOM / @SOM | | Output masking |
|--------------------|-------------|--|
| Getting | Command | @GOM, ch |
| | Response | @GOM, ch, left, right, top, bottom |
| Setting | Command | @SOM, ch, left, right, top, bottom |
| | Response | @SOM, ch, left, right, top, bottom |
| Parameter | | ch: Output channel 1 = OUT1 to 4 = OUT4 left: Left side masking Horizontal output position (0 or larger) to right side masking [Default] 0 right: Right side masking Left side masking to Horizontal output position + horizontal output size (horizontal output resolution or smaller) [Default] Horizontal output resolution top: Top side masking Vertical output position (0 or larger) to bottom side masking [Default] 0 bottom: Bottom side masking Top side masking to vertical output position + vertical output size (vertical output resolution or smaller) [Default] Vertical output resolution |
| Getting example | Command | @GOM,1 |
| | Response | @GOM,1,0,1920,0,1080 |
| | Description | Getting the set OUT1 output masking. Left: 0, right: 1920, top: 0, bottom: 1080 |
| Setting example | Command | @SOM,1,0,1920,0,1080 |
| | Response | @SOM,1,0,1920,0,1080 |
| | Description | Setting OUT1 output masking to 0 for left, 1920 for right, 0 for top, and 1080 for bottom. |
| Remarks | | — |

| @OAS | | Output automatic sizing |
|-----------------|-------------|---|
| Setting | Command | @OAS, ch_1 (, ch_2···) |
| | Response | @OAS, ch_1 (, ch_2···) |
| Parameter | | ch_1-4: Output channel 0 = All outputs, 1 = OUT1 to 4 = OUT4 |
| Setting example | Command | @OAS,1 |
| | Response | @OAS,1 |
| | Description | Initializing the following settings in order to display OUT1 output images on the full screen: @GOP / @SOP Output position @GOS / @SOS Output size @GOM / @SOM Output masking |
| Remarks | | — |

| @GBC / @SBC | | Background color |
|--------------------|-------------|---|
| Getting | Command | @GBC, ch <input type="checkbox"/> |
| | Response | @GBC, ch, red, green, blue <input type="checkbox"/> |
| Setting | Command | @SBC, ch_1, red_1, green_1, blue_1 (, ch_2, red_2, green_2, blue_2····) <input type="checkbox"/> |
| | Response | @SBC, ch_1, red_1, green_1, blue_1 (, ch_2, red_2, green_2, blue_2····) <input type="checkbox"/> |
| Parameter | | ch: Output channel 1 = OUT1 to 4 = OUT4 |
| | | ch_1-4: Output channel 0 = All outputs, 1 = OUT1 to 4 = OUT4 |
| | | red / red_1-4 : Background color (Red) green / green_1-4 : Background color (Green) blue / blue_1-4 : Background color (Blue) 0 to 255 [Default] 0 (Black) |
| Getting example | Command | @GBC,1 <input type="checkbox"/> |
| | Response | @GBC,1,128,128,128 <input type="checkbox"/> |
| | Description | Getting the set OUT1 background color. RGB: 128 (Gray) |
| Setting example | Command | @SBC,1,128,128,128 <input type="checkbox"/> |
| | Response | @SBC,1,128,128,128 <input type="checkbox"/> |
| | Description | Setting OUT1 background color to 128 (Gray) for all RGB. |
| Remarks | | — |

3.3.5 Video processing

| @GOR / @SOR | | Video processing mode |
|-----------------|-------------|---|
| Getting | Command | @GOR ↵ |
| | Response | @GOR, mode ↵ |
| Setting | Command | @SOR, mode ↵ |
| | Response | @SOR, mode ↵ |
| Parameter | | mode: Video processing mode 0 = Normal mode [Default], 1 = Video combination mode 2 = 4K mode |
| Getting example | Command | @GOR ↵ |
| | Response | @GOR,2 ↵ |
| | Description | Getting the video processing mode. 4K mode. |
| Setting example | Command | @SOR,2 ↵ |
| | Response | @SOR,2 ↵ |
| | Description | Setting this menu to 4K mode. |
| Remarks | | — |

| @GPR / @SPR | | Window display priority |
|-----------------|-------------|---|
| Getting | Command | @GPR ↵ |
| | Response | @GPR, priority_1, priority_2, ..., priority_4 ↵ |
| Setting | Command | @SPR, priority_1, priority_2, ..., priority_4 ↵ |
| | Response | @SPR, priority_1, priority_2, ..., priority_4 ↵ |
| Parameter | | priority_1-4: Window priority 1 = priority 1 (high) to 4 = priority 4 (low) [Default] 1,2,3,4 (WINDOW1 to WINDOW4) WINDOW1>WINDOW2>WINDOW3>WINDOW4 |
| Getting example | Command | @GPR ↵ |
| | Response | @GPR,2,4,1,3 ↵ |
| | Description | Getting the set window priority: WINDOW1 to WINDOW4: WINDOW3>WINDOW1>WINDOW4>WINDOW2 |
| Setting example | Command | @SPR,4,3,2,1 ↵ |
| | Response | @SPR,4,3,2,1 ↵ |
| | Description | Setting this menu: WINDOW1 to WINDOW 4: WINDOW4>WINDOW3>WINDOW2>WINDOW1 |
| Remarks | | Priorities have to be set for all four windows. |

| @GOI / @SOI | | Flip horizontal |
|--------------------|-------------|---|
| Getting | Command | @GOI |
| | Response | @GOI, flip_1, flip_2, ..., flip_4 |
| Setting | Command | @SOI, window_1, flip_1, (window_2, flip_2, ..., window_4, flip_4) |
| | Response | @SOI, window_1, flip_1, (window_2, flip_2, ..., window_4, flip_4) |
| Parameter | | flip_1-4: Flip horizontal 0 = OFF [Default], 1 = ON |
| Getting example | Command | @GOI |
| | Response | @GOI,0,1,0,0 |
| | Description | Getting the Flip horizontal setting. WINDOW2: Horizontal flip ON Other windows: Horizontal flip OFF |
| Setting example | Command | @SOI,3,1 |
| | Response | @SOI,3,1 |
| | Description | Setting the WINDOW3 to horizontal flip ON. |
| Remarks | | An error occurs if this menu is set while 4K mode is enabled. 【See: @GOR / @SOR Video processing mode】 |

| @GWV / @SWV | | Hiding window |
|--------------------|-------------|---|
| Getting | Command | @GWV |
| | Response | @GWV, invisible_1, invisible_2, ..., invisible_4 |
| Setting | Command | @SWV, window_1, invisible_1, (window_2, invisible_2, ..., window_4, invisible_4) |
| | Response | @SWV, window_1, invisible_1, (window_2, invisible_2, ..., window_4, invisible_4) |
| Parameter | | invisible_1-4: Hiding window setting 0 = Display [Default], 1 = Hide window_1-4: Window 0 = All WINDOW, 1 = WINDOW1 to 4 = WINDOW4 |
| Getting example | Command | @GWV |
| | Response | @GWV,0,1,0,0 |
| | Description | Getting the hiding window setting. WINDOW2: Hide; Other windows: Display |
| Setting example | Command | @SWV,2,0 |
| | Response | @SWV,2,0 |
| | Description | Setting the WINDOW2 to display. |
| Remarks | | — |

3.3.6 Image quality

| @GFL / @SFL | | Sharpness |
|--------------------|-------------|--|
| Getting | Command | @GFL |
| | Response | @GFL, sharp_1, sharp_2, sharp_3, sharp_4, ..., sharp_8 |
| Setting | Command | @SFL, ch_1, sharp_1 (, ch_2, sharp_2...) |
| | Response | @SFL, ch_1, sharp_1 (, ch_2, sharp_2...) |
| Parameter | | sharp_1-8: Input sharpness -5 to +15 [Default] 0 |
| | | ch_1-8: Input channel 0 = All inputs, 1 = IN1 to 8 = IN8 |
| Getting example | Command | @GFL |
| | Response | @GFL,5,0,0,0,0,0,0 |
| | Description | Getting sharpness setting. IN1: +5, other input channels: 0 |
| Setting example | Command | @SFL,1,5 |
| | Response | @SFL,1,5 |
| | Description | Setting the IN1 sharpness to +5. |
| Remarks | | — |

| @GBR / @SBR | | Input brightness |
|--------------------|-------------|--|
| Getting | Command | @GBR |
| | Response | @GBR, bright_1, bright_2, bright_3, bright_4, ..., bright_8 |
| Setting | Command | @SBR, ch_1, bright_1 (, ch_2, bright_2...) |
| | Response | @SBR, ch_1, bright_1 (, ch_2, bright_2...) |
| Parameter | | bright_1-8 : Input brightness 80 to 120 [Default] 100 |
| | | ch_1-8: Input channel 0 = All inputs, 1 = IN1 to 8 = IN8 |
| Getting example | Command | @GBR |
| | Response | @GBR,110,100,100,100,100,100,100 |
| | Description | Getting brightness setting. IN1: 110 %, other input channels: 100 % |
| Setting example | Command | @SBR,3,110 |
| | Response | @SBR,3,110 |
| | Description | Setting the IN3 brightness to 110%. |
| Remarks | | — |

| @GCO / @SCO | | Input contrast |
|--------------------|-------------|---|
| Getting | Command | @GCO, ch |
| | Response | @GCO, ch, red, green, blue |
| Setting | Command | @SCO, ch_1, red_1, green_1, blue_1 (, ch_2, red_2, green_2, blue_2···) |
| | Response | @SCO, ch_1, red_1, green_1, blue_1 (, ch_2, red_2, green_2, blue_2···) |
| Parameter | | ch: Input channel 1 = IN1 to 8 = IN8 ch_1-8: Input channel 0 = All inputs, 1 = IN1 to 8 = IN8 red / red_1-8 : Input contrast (Red) green / green_1-8 : Input contrast (Green) blue / blue_1-8 : Input contrast (Blue) 0 to 200 [Default] 100 |
| Getting example | Command | @GCO,3 |
| | Response | @GCO,3,105,100,95 |
| | Description | Getting IN3 contrast setting. Red: 105 %, Green: 100 %, Blue: 95 % |
| Setting example | Command | @SCO,3,105,100,95 |
| | Response | @SCO,3,105,100,95 |
| | Description | Setting IN3 contrast to 105% for red, 100% for green, 95% for blue. |
| Remarks | | — |

| @GHU / @SHU | | Hue |
|--------------------|-------------|---|
| Getting | Command | @GHU |
| | Response | @GHU, hue_1, hue_2, hue_3, hue_4, ···, hue_8 |
| Setting | Command | @SHU, ch_1, hue_1 (, ch_2, hue_2···) |
| | Response | @SHU, ch_1, hue_1 (, ch_2, hue_2···) |
| Parameter | | hue_1-8: Input hue 0 to 359 [Default] 0 ch_1-8: Input channel 0 = All inputs, 1 = IN1 to 8 = IN8 |
| Getting example | Command | @GHU |
| | Response | @GHU,60,0,0,0,0,0,0 |
| | Description | Getting the set HUEs. IN1: 60°, other inputs: 0° |
| Setting example | Command | @SHU,1,60 |
| | Response | @SHU,1,60 |
| | Description | Setting IN1 HUE to 60°. |
| Remarks | | Hue can be set up to 359 °. However, if the dot clock of the input signal exceeds 170 MHz, 0 ° is applied regardless of this setting. |

| @GST / @SST | | Saturation |
|--------------------|-------------|---|
| Getting | Command | @GST |
| | Response | @GST, saturation_1, saturation_2, saturation_3, saturation_4, ..., saturation_8 |
| Setting | Command | @SST, ch_1, saturation_1 (, ch_2, saturation_2...) |
| | Response | @SST, ch_1, saturation_1 (, ch_2, saturation_2...) |
| Parameter | | saturation_1-8: Input saturation 0 to 200 [Default] 100 |
| | | ch_1-8: Input channel 0 = All inputs, 1 = IN1 to 8 = IN8 |
| Getting example | Command | @GST |
| | Response | @GST,100,100,100,100,105,100,100,100 |
| | Description | Getting the set saturations. IN5: 105 %, other inputs: 100 % |
| Setting example | Command | @SST,5,105 |
| | Response | @SST,5,105 |
| | Description | Setting IN5 saturation to 105%. |
| Remarks | | Hue can be set up to 200%. However, if the dot clock of the input signal exceeds 170 MHz, 100% is applied regardless of this setting. |

| @GSU / @SSU | | Black level |
|--------------------|-------------|---|
| Getting | Command | @GSU |
| | Response | @GSU, setup_1, setup_2, setup_3, setup_4, ..., setup_8 |
| Setting | Command | @SSU, ch_1, setup_1 (, ch_2, setup_2...) |
| | Response | @SSU, ch_1, setup_1 (, ch_2, setup_2...) |
| Parameter | | setup_1-8: Input black level -20 = -20×0.5 (-10.0 %) to +20 = $+20 \times 0.5$ (+10.0 %) [Default] $\pm 0 = \pm 0.0$ % |
| | | ch_1-8: Input channel 0 = All inputs, 1 = IN1 to 8 = IN8 |
| Getting example | Command | @GSU |
| | Response | @GSU,0,0,0,0,15,0,0,0 |
| | Description | Getting the input black level. IN5: +7.5%, other inputs: 0%. |
| Setting example | Command | @SSU,5,15 |
| | Response | @SSU,5,15 |
| | Description | Setting the IN5 black level to +7.5%. |
| Remarks | | — |

| @IDC | | Input default color |
|-----------------|-------------|--|
| Setting | Command | @IDC, ch_1 (, ch_2···) ↵ |
| | Response | @IDC, ch_1 (, ch_2···) ↵ |
| Parameter | | ch_1-8: Input channel 0 = All inputs, 1 = IN1 to 8 = IN8 |
| Setting example | Command | @IDC,1 ↵ |
| | Response | @IDC,1 ↵ |
| | Description | Initialize the following settings of IN1: @GFL / @SFL Sharpness @GBR / @SBR Input brightness @GCO / @SCO Input contrast @GHU / @SHU Hue @GST / @SST Saturation @GSU / @SSU Black level |
| Remarks | | — |

| @GOB / @SOB | | Output brightness |
|--------------------|-------------|---|
| Getting | Command | @GOB ↵ |
| | Response | @GOB, bright_1, bright_2, bright_3, ···, bright_4 ↵ |
| Setting | Command | @SOB, ch_1, bright_1 (, ch_2, bright_2···) ↵ |
| | Response | @SOB, ch_1, bright_1 (, ch_2, bright_2···) ↵ |
| Parameter | | bright_1-4: Output brightness 80 to 120 [Default] 100 ch_1-4: Output channel 0 = All outputs, 1 = OUT1 to 4 = OUT4 |
| Getting example | Command | @GOB ↵ |
| | Response | @GOB,110,110,100,100 ↵ |
| | Description | Getting the output brightness. OUT1 and OUT2: 110 %, OUT3 and OUT4: 100 % |
| Setting example | Command | @SOB,1,110 ↵ |
| | Response | @SOB,1,110 ↵ |
| | Description | Setting the OUT1 brightness to 110%. |
| Remarks | | — |

| @GOC / @SOC | | Output contrast |
|--------------------|-------------|--|
| Getting | Command | @GOC, ch |
| | Response | @GOC, ch, red, green, blue |
| Setting | Command | @SOC, ch_1, red_1, green_1, blue_1 (, ch_2, red_2, green_2, blue_2····) |
| | Response | @SOC, ch_1, red_1, green_1, blue_1 (, ch_2, red_2, green_2, blue_2····) |
| Parameter | | ch: Output channel 1 = OUT1 to 4 = OUT4 ch_1-4: Output channel 0 = All outputs, 1 = OUT1 to 4 = OUT4 red / red_1-4 : Output contrast (Red) green / green_1-4: Output contrast (Green) blue / blue_1-4 : Output contrast (Blue) 0 to 200 [Default] 100 |
| Getting example | Command | @GOC,1 |
| | Response | @GOC,1,105,100,95 |
| | Description | Getting the OUT1 contrast setting. Red: 105%, green: 100%, blue: 95% |
| Setting example | Command | @SOC,1,105,100,95 |
| | Response | @SOC,1,105,100,95 |
| | Description | Setting the OUT1 contrast to 105% for red, 100% for green, 95% for blue. |
| Remarks | | — |

| @GGM / @SGM | | Output gamma |
|--------------------|-------------|--|
| Getting | Command | @GGM |
| | Response | @GGM, out_1, out_2, out_3, out_4 |
| Setting | Command | @SGM, ch_1, gamma_1 (, ch_2, gamma_2····) |
| | Response | @SGM, ch_1, gamma_1 (, ch_2, gamma_2····) |
| Parameter | | out_1-4 / gamma_1-4: Output gamma 1 = 0.1 to 30 = 3.0 [Default] 10 = 1.0 ch_1-4: Output channel 0 = All outputs, 1 = OUT1 to 4 = OUT4 |
| Getting example | Command | @GGM |
| | Response | @GGM,22,10,10,10 |
| | Description | Getting the set output gamma. OUT1: 2.2, Others: 1.0 |
| Setting example | Command | @SGM,1,22 |
| | Response | @SGM,1,22 |
| | Description | Setting the OUT1 output gamma to 2.2. |
| Remarks | | — |

| @ODC | | Output default color |
|-----------------|-------------|--|
| Setting | Command | @ODC, ch_1 (, ch_2···) ↵ |
| | Response | @ODC, ch_1 (, ch_2···) ↵ |
| Parameter | | ch_1-4: Output channel 0 = All outputs, 1 = OUT1 to 4 = OUT4 |
| Setting example | Command | @ODC,1 ↵ |
| | Response | @ODC,1 ↵ |
| | Description | Initializing OUT1 image quality settings. @GOB / @SOB Output brightness @GOC / @SOC Output contrast @GGM / @SGM Output gamma |
| Remarks | | — |

3.3.7 Input settings

| @GDT / @SDT | | No-signal-input monitoring |
|--------------------|-------------|--|
| Getting | Command | @GDT ↵ |
| | Response | @GDT, time_1, time_2, time_3, time_4, ···, time_8 ↵ |
| Setting | Command | @SDT, ch_1, time_1 (, ch_2, time_2···) ↵ |
| | Response | @SDT, ch_1, time_1 (, ch_2, time_2···) ↵ |
| Parameter | | time_1-8: No-signal-input monitoring 0 = OFF, 2000 = 2 sec to 15000 = 15 sec [Default] 10000 = 10 sec Set the value by 100 ms. If you set a value other than 0 for the lower 2 digits, these values will be rounded down. (For example, if you set it to 2955, the monitoring time is set to 2900 ms.) ch_1-8: Input channel 0 = All digital inputs, 1 = IN1 to 8 = IN8 |
| Getting example | Command | @GDT ↵ |
| | Response | @GDT,6000,10000,10000,4000,4000,4000,4000,4000 ↵ |
| | Description | Getting the set monitoring time of input video signal. IN1: 6000 ms. (6 sec.), IN2 and IN3: 10000 ms. (10 sec.), IN4 and IN8: 4000 ms. (4 sec.) |
| Setting example | Command | @SDT,3,6000 ↵ |
| | Response | @SDT,3,6000 ↵ |
| | Description | Setting the monitoring time of IN3 to 6000 ms. (6 sec.). |
| Remarks | | These commands are only for digital input. IN7 and IN8 are available only if "1" (Digital signal) is selected for " @GIN / @SIN Signal selection of DVI input connector ". If "0" (Analog signal) is selected, "-1" is returned. |

| @GHE / @SHE | | HDCP input enabled/disabled |
|-----------------|-------------|--|
| Getting | Command | @GHE |
| | Response | @GHE, hdcp_1, hdcp_2, hdcp_3, hdcp_4, ..., hdcp_8 |
| Setting | Command | @SHE, ch_1, hdcp_1 (, ch_2, hdcp_2...) |
| | Response | @SHE, ch_1, hdcp_1 (, ch_2, hdcp_2...) |
| Parameter | | hdcp_1-8 : HDCP input enabled/disabled 0 = DISABLE, 1 = ENABLE [Default] ENABLE |
| | | ch_1-8: Input channel 0 = All digital inputs, 1 = IN1 to 8 = IN8 |
| Getting example | Command | @GHE |
| | Response | @GHE,1,1,0,1,1,1,1,1 |
| | Description | Getting HDCP input enabled/disabled. IN3: disables HDCP input, other input channels: enables HDCP input |
| Setting example | Command | @SHE,1,0 |
| | Response | @SHE,1,0 |
| | Description | Setting IN1 HDCP input to be disabled. |
| Remarks | | These commands are only for digital input. IN7 and IN8 are available only if "1" (Digital signal) is selected for " @GIN / @SIN Signal selection of DVI input connector ". If "0" (Analog signal) is selected, "-1" is returned. |

| @GAI / @SAI | | Analog input type |
|-----------------|-------------|---|
| Getting | Command | @GAI |
| | Response | @GAI, type_1, type_2 |
| Setting | Command | @SAI, ch_1, type_1 (, ch_2, type_2) |
| | Response | @SAI, ch_1, type_1 (, ch_2, type_2) |
| Parameter | | type_1-2: Signal type 0 = AUTO [Default], 1 = RGB, 2 = YPbPr, 3 = VIDEO AUTO, 4 = VIDEO, 5 = Y/C |
| | | ch_1-2: Input channel 0 = All analog inputs, 7 = IN7, 8 = IN8 |
| Getting example | Command | @GAI |
| | Response | @GAI,0,2 |
| | Description | Getting signal type of analog input. IN7: AUTO, IN8: YPbPr |
| Setting example | Command | @SAI,0,2 |
| | Response | @SAI,0,2 |
| | Description | Setting the signal type of IN7 and IN8 to YPbPr. |
| Remarks | | These commands are only for analog input. IN7 and IN8 are available only if "0" (Analog signal) is selected for " @GIN / @SIN Signal selection of DVI input connector ". If "1" (Digital signal) is selected, "-1" is returned. |

| @GID / @SID | | Automatic detection of input video interruption |
|--------------------|-------------|--|
| Getting | Command | @GID ↵ |
| | Response | @GID, detect_1, detect_2, detect_3, detect_4, ..., detect_8 ↵ |
| Setting | Command | @SID, ch_1, detect_1 (, ch_2, detect_2...) ↵ |
| | Response | @SID, ch_1, detect_1 (, ch_2, detect_2...) ↵ |
| Parameter | | detect_1-8: Automatic detection 0 = OFF, 1 = ON [Default] |
| | | ch_1-8: Input channel 0 = All inputs, 1 = IN1 to 8 = IN8 |
| Getting example | Command | @GID ↵ |
| | Response | @GID,1,1,1,1,1,0,1,1 ↵ |
| | Description | Getting the setting of automatic detection of input video interruption. IN6: If input video signal is interrupted, the video output is not turned off instantly. Other inputs: OFF |
| Setting example | Command | @SID,2,0 ↵ |
| | Response | @SID,2,0 ↵ |
| | Description | Setting IN2 automatic detection to OFF ("0"). If input video signal is interrupted, not to turn off the video output instantly. |
| Remarks | | — |

| @GIN / @SIN | | Signal selection of DVI input connector |
|--------------------|-------------|--|
| Getting | Command | @GIN ↵ |
| | Response | @GIN, signal_1, signal_2 ↵ |
| Setting | Command | @SIN, ch_1, signal_1 (, ch_2, signal_2) ↵ |
| | Response | @SIN, ch_1, signal_1 (, ch_2, signal_2) ↵ |
| Parameter | | signal_1-2: Signal selection of DVI input connectors (IN7, IN8) 0 = Analog signal, 1 = Digital signal [Default] |
| | | ch_1-2: Input channel 0 =All analog inputs, 7 = IN7, 8 = IN8 |
| Getting example | Command | @GIN ↵ |
| | Response | @GIN,0,0 ↵ |
| | Description | Getting the set DVI input signal. IN7 and IN8: Analog input signal |
| Setting example | Command | @SIN,8,1 ↵ |
| | Response | @SIN,8,1 ↵ |
| | Description | Setting IN8 to digital input signal. |
| Remarks | | — |

| @GIA / @SIA | | HDBaseT input long reach mode |
|-----------------|-------------|---|
| Getting | Command | @GIA, ch <input type="checkbox"/> |
| | Response | @GIA, ch, mode <input type="checkbox"/> |
| Setting | Command | @SIA, ch, mode <input type="checkbox"/> |
| | Response | @SIA, ch, mode <input type="checkbox"/> |
| Parameter | | ch: Input channel 5 = IN5, 6 = IN6 Make sure to set this menu to "5" or "6". |
| | | mode: Setting mode 0 = long reach mode OFF [Default], 1 = long reach mode ON |
| Getting example | Command | @GIA,5 <input type="checkbox"/> |
| | Response | @GIA,5,0 <input type="checkbox"/> |
| | Description | Getting long reach mode setting of IN5. Setting long reach mode of IN5 to OFF. |
| Setting example | Command | @SIA,6,1 <input type="checkbox"/> |
| | Response | @SIA,6,1 <input type="checkbox"/> |
| | Description | Setting long reach mode of IN6 to ON. |
| Remarks | | If this menu is set to "ON", resolutions up to 1080p (24 bit) are supported. If it exceeds 1080p (24 bit), video signal cannot be received. |

| @GFX / @SFX | | Fixing settings for input signal |
|-----------------|-------------|---|
| Getting | Command | @GFX ch [↵] |
| | Response | @GFX, ch, mode (, aspect, analog, audio) [↵] |
| Setting | Command | @SFX, ch, mode (, aspect, analog, audio) [↵] |
| | Response | @SFX, ch, mode (, aspect, analog, audio) [↵] |
| Parameter | | <p>ch: Input channel 1 = IN1 to 8 = IN8</p> <p>mode : Setting mode 0 = SELECTED, 1 = ALL FIXED</p> <p>Available only if the "mode" is selected to "0" (SELECTED)</p> <p>aspect: Aspect ratio 0 = OFF [Default], 1 = ON(FIXED)</p> <p>analog: Signal type of analog input (For digital input, select "0") 0 = OFF, 1 = ON(FIXED) [Default]</p> <p>audi : Audio input level (For analog input, select "0") 0 = OFF, 1 = ON(FIXED) [Default]</p> |
| Getting example | Command | @GFX, 1 [↵] |
| | Response | @GFX, 1,0,1,0,0 [↵] |
| | Description | <p>Getting setting fixation of each input signal. (For analog inputs)</p> <p>IN1 aspect ratio: current setting, signal type of analog input: setting of each input signal.</p> <p>Audio input level is disabled.</p> |
| Setting example | Command | @SFX,2,1 [↵] |
| | Response | @SFX,2,1 [↵] |
| | Description | <p>IN2: Fixing settings for each input to the current settings.</p> <p>Completed normally.</p> |
| Remarks | | <p>When digital input channel is acquired, "0" is returned for the Parameter of analog signal type. ("0" is an invalid value.)</p> <p>When analog input channel is acquired, "0" is returned for the Parameter of audio input level. ("0" is an invalid value.)</p> <p>Input channels IN7 and IN8: digital input/analog input selectable. 【See: @GIN / @SIN Signal selection of DVI input connector】</p> |

3.3.8 Input timing

| @AIS / @AIT | | Automatic measurement |
|-----------------|-------------|---|
| Setting | Description | Starting automatic measurement of the start position and display period. |
| | Command | @AIS, ch ↵ |
| | Response | @AIS, ch ↵ |
| Setting | Description | Starting automatic measurement with a desired aspect ratio. |
| | Command | @AIT, ch (, mode) ↵ |
| | Response | @AIT, ch (, mode) ↵ |
| Parameter | | ch: Input channel 7 = IN7, 8 = IN8 mode: Measurement mode -1 = NEXT ASPECT, 0 = 4:3, 1 = 5:4, 2 = 5:3, 3 = 16:9, 4 = 16:10 If you select "NEXT ASPECT", the next aspect ratio will be selected in order every time the automatic measurement is executed. If you do not set any mode parameter, "NEXT ASPECT" mode will be applied. |
| Setting example | Command | @AIS,8 ↵ |
| | Response | @AIS,8 ↵ |
| | Description | Starting the automatic measurement of IN8 the start position and display period. |
| Setting example | Command | @AIT,8,0 ↵ |
| | Response | @AIT,8,0 ↵ |
| | Description | Starting the automatic measurement of IN8 input timing setting at the aspect ratio of "4:3". |
| Setting example | Command | @AIS,8 ↵ |
| | Response | @ERR,7 ↵ |
| | Description | If the automatic measurement fails, an error is returned. |
| Remarks | | These commands are valid only if analog RGB/analog YPbPr signal is input. |

| @GHT / @SHT | | The total number of horizontal dots |
|--------------------|-------------|---|
| Getting | Command | @GHT ↵ |
| | Response | @GHT, h_total_1, h_total_2, h_total_3, h_total_4, ..., h_total_8 ↵ |
| Setting | Command | @SHT, ch, h_total ↵ |
| | Response | @SHT, ch, h_total ↵ |
| Parameter | | h_total_1-8 / h_total: The total number of horizontal dots 400 to 4125 (sampling block should be 13 MHz to 162 MHz) [Default] depends on input signal |
| | | ch: Input channel 0 =All analog inputs, 7 = IN7, 8 = IN8 |
| Getting example | Command | @GHT ↵ |
| | Response | @GHT,2200,2200,0,2640,1344,1792,0,0 ↵ |
| | Description | Getting the total number of horizontal dots. "0" is returned to channels without input signal. |
| Setting example | Command | @SHT,8,1344 ↵ |
| | Response | @SHT,8,1344 ↵ |
| | Description | Setting the total number of IN8 horizontal dots to "1344". |
| Setting example | Command | @SHT,8,1344 ↵ |
| | Response | @ERR,3 ↵ |
| | Description | If analog RGB signal or analog YPbPr signal is not input, an error is returned. |
| Remarks | | Getting command acquires all channels' statuses. Setting commands are valid only if analog RGB/analog YPbPr signal is input. |

| @GHS / @SHS | | Horizontal start position |
|--------------------|-------------|--|
| Getting | Command | @GHS |
| | Response | @GHS, h_start_1, h_start_2, h_start_3, h_start_4, ..., h_start_8 |
| Setting | Command | @SHS, ch, h_start |
| | Response | @SHS, ch, h_start |
| Parameter | | h_start_1-8 / h_start : Horizontal start position 64 to 2900 (should be [the total number of horizontal dots – horizontal display period] or less) [Default] depends on input signal |
| | | ch: Input channel 0 = All inputs, 1 = IN1 to 8 = IN8 |
| Getting example | Command | @GHS |
| | Response | @GHS,192,192,496,0,296,0,378,0 |
| | Description | Getting the horizontal start position. “0” is returned to channels without input signal. |
| Setting example | Command | @SHS,5,296 |
| | Response | @SHS,5,296 |
| | Description | Setting IN5 horizontal start position to 296 dots. |
| Setting example | Command | @SHS,6,296 |
| | Response | @ERR,3 |
| | Description | If no signal is input, an error is returned. |
| Remarks | | Setting command is valid only for video signal except for 4K video signal. If 4K video signal is input, only Getting commands are available. |

| @GHD / @SHD | | Horizontal display period |
|--------------------|-------------|---|
| Getting | Command | @GHD |
| | Response | @GHD, h_disp_1, h_disp_2, h_disp_3, h_disp_4, ..., h_disp_8 |
| Setting | Command | @SHD, ch, h_disp |
| | Response | @SHD, ch, h_disp |
| Parameter | | h_disp_1-8 / h_disp : Horizontal display period 64 to 2900 (should be [the total number of horizontal dots - 64] or less) [Default] depends on input signal |
| | | ch: Input channel 0 = All inputs, 1 = IN1 to 8 = IN8 |
| Getting example | Command | @GHD |
| | Response | @GHD,1920,1920,0,1920,1024,1360,0,0 |
| | Description | Getting horizontal display period. “0” is returned to channels without input signal. |
| Setting example | Command | @SHD,5,1024 |
| | Response | @SHD,5,1024 |
| | Description | Setting IN5 horizontal display period to 1024 dots. |
| Setting example | Command | @SHD,6,1024 |
| | Response | @ERR,3 |
| | Description | If no signal is input, an error is returned. |
| Remarks | | Setting commands: valid only for video signal except for 4K video signal. If 4K video signal is input, only getting commands are valid. |

| @GVS / @SVS | | Vertical start position |
|--------------------|-------------|---|
| Getting | Command | @GVS |
| | Response | @GVS, v_start_1, v_start_2, v_start_3, v_start_4, ..., v_start_8 |
| Setting | Command | @SVS, ch, v_start |
| | Response | @SVS, ch, v_start |
| Parameter | | v_start_1-8 / v_start : Vertical start position 10 to 2048 (should be [the total number of vertical lines - vertical display period] or less) [Default] depends on input signal |
| | | ch: Input channel 0 = All inputs, 1 = IN1 to 8 = IN8 |
| Getting example | Command | @GVS |
| | Response | @GVS,40,0,40,40,35,0,24,0 |
| | Description | Getting the vertical start position. "0" is returned to channels without input signal. |
| Setting example | Command | @SVS,5,35 |
| | Response | @SVS,5,35 |
| | Description | Setting IN5 vertical start position to 35 lines. |
| Setting example | Command | @SVS,6,35 |
| | Response | @ERR,3 |
| | Description | If no signal is input, an error is returned. |
| Remarks | | Setting commands: valid only for video signal except for 4K video signal. If 4K video signal is input, only getting commands are valid. |

| @GVD / @SVD | | Vertical display period |
|--------------------|-------------|---|
| Getting | Command | @GVD |
| | Response | @GVD, v_disp_1, v_disp_2, v_disp_3, v_disp_4, ..., v_disp_8 |
| Setting | Command | @SVD, ch, v_disp |
| | Response | @SVD, ch, v_disp |
| Parameter | | v_disp_1-8 / v_disp: Vertical display period 10 to 2048 (should be [the total number of vertical lines - 10] or less) [Default] depends on input signal |
| | | ch: Input channel 0 = All inputs, 1 = IN1 to 8 = IN8 |
| Getting example | Command | @GVD |
| | Response | @GVD,0,1080,1080,900,768,0,900,0 |
| | Description | Getting vertical display period. "0" is returned to channels without input signal. |
| Setting example | Command | @SVD,5,768 |
| | Response | @SVD,5,768 |
| | Description | Setting IN5 vertical display period to 768 lines. |
| Setting example | Command | @SVD,5,768 |
| | Response | @ERR,3 |
| | Description | If no signal is input, an error is returned. |
| Remarks | | Setting commands: valid only for video signal except for 4K video signal. If 4K video signal is input, only getting commands are valid. |

| @GIS / @SIS | | Automatic measurement of start position |
|--------------------|-------------|---|
| Getting | Command | @GIS ↵ |
| | Response | @GIS, mode_1, mode_2 ↵ |
| Setting | Command | @SIS, ch, mode ↵ |
| | Response | @SIS, ch, mode ↵ |
| Parameter | | <p>mode_1-2 / mode: Automatic measurement 0 = All inputs from this input channel are not measured automatically. 1 = Current input signal is not measured automatically. 2 = Current input signal is measured automatically. [Default]</p> <p>ch: Input channel 0 = All analog inputs, 7 = IN7, 8 = IN8</p> |
| Getting example | Command | @GIS ↵ |
| | Response | @GIS,0,2 ↵ |
| | Description | Getting the setting of Automatic measurement of the start position. IN7: not measured automatically, IN8: measured automatically. |
| Setting example | Command | @SIS,8,1 ↵ |
| | Response | @SIS,8,1 ↵ |
| | Description | Setting signal that is currently input from IN8 to "1" (Current input signal is not measured automatically). |
| Remarks | | <p>These commands are only for analog input.</p> <p>IN7 and IN8 are available only if "0" (Analog signal) is selected for "@GIN / @SIN Signal selection of DVI input connector". If "1" (Digital signal) is selected, "-1" is returned.</p> |

| @GSM / @SSM | | Automatic measurement when unregistered signal is input |
|--------------------|-------------|---|
| Getting | Command | @GSM ↵ |
| | Response | @GSM, mode ↵ |
| Setting | Command | @SSM, mode ↵ |
| | Response | @SSM, mode ↵ |
| Parameter | | <p>mode: Automatic measurement 0 = Not execute, 1 = Execute [Default]</p> |
| Getting example | Command | @GSM ↵ |
| | Response | @GSM,1 ↵ |
| | Description | Getting the set automatic measurement mode when unregistered signal is input. Automatic measurement is set to "1" (Execute). |
| Setting example | Command | @SSM,1 ↵ |
| | Response | @SSM,1 ↵ |
| | Description | Setting the automatic measurement to be executed when unregistered signal is input. |
| Remarks | | — |

| @RTT | | Loading device data |
|-----------------|-------------|---|
| Setting | Command | @RTT, ch (, table) ↵ |
| | Response | @RTT, ch (, table) ↵ |
| Parameter | | <p>ch: Input channel 1 = IN1 to 8 = IN8</p> <p>table: Device table 1 to 99 (Registered device data), 100 to 100+n (Preset device data. "n" varies depending on input signal, but 0 for most cases.)</p> <p>Only for analog input, specify the device table.</p> |
| Setting example | Command | @RTT,1 ↵ |
| | Response | @RTT,1 ↵ |
| | Description | Reconfiguring IN1 input timing setting to the value detected automatically. |
| Setting example | Command | @RTT,6,2 ↵ |
| | Response | @RTT,6,2 ↵ |
| | Description | Setting IN6 input timings to the values saved in the device table 2. |
| Remarks | | <p>This command is valid only if signal is input.</p> <p>For analog input, this command is valid only if the device data of input signal is registered.</p> |

| @STT | | Registering device data |
|-----------------|-------------|--|
| Setting | Command | @STT, ch, table (, name) ↵ |
| | Response | @STT, ch, table (, name) ↵ |
| Parameter | | <p>ch: Input channel 1 = IN1, 2 = IN2</p> <p>table: Device table 1 to 99</p> <p>name: Device table name Up to 14 characters from 20 to 7D of ASCII code.</p> <p>You can skip "Device table name". If you skip it, only input timing setting is saved. However, if no device table name is currently saved, the resolution is saved automatically as the device table name.</p> |
| Setting example | Command | @STT,1,2 ↵ |
| | Response | @STT,1,2 ↵ |
| | Description | Saving IN1 input timing setting in device table 2 without editing the device table name. |
| Setting example | Command | @STT,1,2,XGA 60Hz ↵ |
| | Response | @STT,1,2,XGA 60Hz ↵ |
| | Description | Saving the current IN8 input timing setting in device table 2 with the name of "XGA 60Hz". |
| Remarks | | This command is valid only if analog RGB / YPbPr signal is input. |

| @GTK / @STK | | Tracking |
|-----------------|-------------|--|
| Getting | Command | @GTK ↵ |
| | Response | @GTK, track_1, track_2 ↵ |
| Setting | Command | @STK, ch_1, track_1 (, ch_2 , track_2) ↵ |
| | Response | @STK, ch_1, track_1 (, ch_2 , track_2) ↵ |
| Parameter | | track_1-2: Tracking 0 to 63 [Default] 0 |
| | | ch_1-2: Input channel 0 = All analog inputs, 7 = IN7, 8 = IN8 |
| Getting example | Command | @GTK ↵ |
| | Response | @GTK,4,0 ↵ |
| | Description | Getting the set tracking. If no analog RGB / YPbPr signal is input, "0" is returned. |
| Setting example | Command | @STK,8,4 ↵ |
| | Response | @STK,8,4 ↵ |
| | Description | Setting IN8 tracking to "4". |
| Remarks | | This command is valid only if analog RGB / YPbPr signal is input. If "1" (Digital signal) is selected, "-1" is returned. |

3.3.9 Output settings

| @GEQ / @SEQ | | Output equalizer |
|--------------------|-------------|---|
| Getting | Command | @GEQ |
| | Response | @GEQ, level_1, level_2, level_3, level_4 |
| Setting | Command | @SEQ, ch_1, level_1 (, ch_2, level_2···) |
| | Response | @SEQ, ch_1, level_1 (, ch_2, level_2···) |
| Parameter | | level_1-4: Output mode 0 = OFF [Default], 1 = LOW, 2 = MIDDLE, 3 = HIGH ch_1-4: Output channel 0 = All HDMI outputs, 1 = OUT1A to 4 = OUT4A |
| Getting example | Command | @GEQ |
| | Response | @GEQ,3,0,3,3 |
| | Description | Getting the set output mode. OUT2A: OFF, other output channels: HIGH |
| Setting example | Command | @SEQ,1,0 |
| | Response | @SEQ,1,0 |
| | Description | Setting the OUT1A output equalizer to OFF. |
| Remarks | | This command is only for HDMI output connectors. |

| @GDM / @SDM | | Output mode |
|--------------------|-------------|--|
| Getting | Command | @GDM |
| | Response | @GDM, mode_1, mode_2, mode_3, mode_4 |
| Setting | Command | @SDM, ch_1, mode_1 (, ch_2, mode_2···) |
| | Response | @SDM, ch_1, mode_1 (, ch_2, mode_2···) |
| Parameter | | mode_1-4: Output mode 0 = DVI MODE, 1 = HDMI RGB MODE, 2 = HDMI YCbCr4:2:2 MODE, 3 = HDMI YCbCr4:4:4 MODE [Default] ch_1-4: Output channel 0 = All outputs, 1 = OUT1 to 4 = OUT4 |
| Getting example | Command | @GDM |
| | Response | @GDM,3,0,3,3 |
| | Description | Getting the set output mode. OUT2: DVI MODE, other output channels: HDMI YCbCr4:4:4 MODE |
| Setting example | Command | @SDM,1,3 |
| | Response | @SDM,1,3 |
| | Description | Setting the OUT1 output mode to "HDMI YCbCr4: 4: 4 MODE" |
| Remarks | | — |

| @GUY / @SUY | | Synchronous signal output when no video signal is input |
|--------------------|-------------|---|
| Getting | Command | @GUY |
| | Response | @GUY, sync_1, sync_2, sync_3, sync_4 |
| Setting | Command | @SUY, ch_1, sync_1 (, ch_2, sync_2···) |
| | Response | @SUY, ch_1, sync_1 (, ch_2, sync_2···) |
| Parameter | | sync_1-4: Synchronous signal output 0 = Not output, 1 = Output [Default] |
| | | ch_1-4: Output channel 0 = All outputs, 1 = OUT1 to 4 = OUT4 |
| Getting example | Command | @GUY |
| | Response | @GUY,1,0,0,0 |
| | Description | Getting synchronous signal output when no video signal is input. OUT1: synchronous signal is output. Other output channels: synchronous signal is not output. |
| Setting example | Command | @SUY,1,1 |
| | Response | @SUY,1,1 |
| | Description | Setting OUT1 to "1" (synchronous signal is output even if video signal is not input). |
| Remarks | | — |

| @GBO / @SBO | | Output video when no video signal is not input |
|--------------------|-------------|--|
| Getting | Command | @GBO |
| | Response | @GBO, video_1, video_2, video_3, video_4 |
| Setting | Command | @SBO, ch_1, video_1 (, ch_2, video_2···) |
| | Response | @SBO, ch_1, video_1 (, ch_2, video_2···) |
| Parameter | | video_1-4: Output video when no video signal is not input 0 = Black, 1 = Blue [Default], 2 = Background color |
| | | ch_1-4: Output channel 0 = All outputs, 1 = OUT1 to 4 = OUT4 |
| Getting example | Command | @GBO |
| | Response | @GBO,1,0,0,0 |
| | Description | Getting the output video when no video signal is input. OUT1: blue screen, other output channels: black screen |
| Setting example | Command | @SBO,1,1 |
| | Response | @SBO,1,1 |
| | Description | Setting OUT1 to output blue when no video signal is input. |
| Remarks | | — |

| @GFF / @SFF | | Video switching effect |
|--------------------|-------------|---|
| Getting | Command | @GFF ↵ |
| | Response | @GFF, switching_1, switching_2, switching_3, switching_4 ↵ |
| Setting | Command | @SFF, ch_1, switching_1 (, ch_2, switching_2···) ↵ |
| | Response | @SFF, ch_1, switching_1 (, ch_2, switching_2···) ↵ |
| Parameter | | switching_1-4: Video switching effect 0 = CUT, 1 = FADE OUT/IN, 2 = FREEZE + FADE OUT/IN [Default], 3 = LEFT→RIGHT WIPE, 4 = RIGHT→LEFT WIPE, 5 = TOP→BOTTOM WIPE, 6 = BOTTOM→TOP WIPE |
| | | ch_1-4: Output channel 0 = All outputs, 1 = OUT1 to 4 = OUT4 |
| Getting example | Command | @GFF ↵ |
| | Response | @GFF,0,0,1,1 ↵ |
| | Description | Getting input channel switching effect. OUT1 and OUT2: CUT, OUT3 and OUT4: FADE OUT/IN |
| Setting example | Command | @SFF,1,1 ↵ |
| | Response | @SFF,1,1 ↵ |
| | Description | Setting OUT1 switching effect to FADE OUT/IN. |
| Remarks | | An error occurs if this menu is set to one of "3" to "6" (WIPE) while video combination mode is enabled. |

| @GFT / @SFT | | Video switching speed |
|--------------------|-------------|--|
| Getting | Command | @GFT ↵ |
| | Response | @GFT, time_1, time_2, time_3, time_4 ↵ |
| Setting | Command | @SFT, ch_1, time_1 (, ch_2, time_2···) ↵ |
| | Response | @SFT, ch_1, time_1 (, ch_2, time_2···) ↵ |
| Parameter | | time_1-4: Switching speed 100 = 0.1 sec. to 2000 = 2 sec. [Default] 350 = 0.35 sec. Set the value by 10 ms. If you set a value other than 0 for the lower 1 digits, these values will be rounded down. (For example, if you set it to 395, the speed is set to 390 ms.) |
| | | ch_1-4: Output channel 0 = All outputs, 1 = OUT1 to 4 = OUT4 |
| Getting example | Command | @GFT ↵ |
| | Response | @GFT,400,400,350,350 ↵ |
| | Description | Getting the set switching speed of video input channel. OUT1 and OUT2: 400 ms, OUT3 and OUT4: 350 ms |
| Setting example | Command | @SFT,1,400 ↵ |
| | Response | @SFT,1,400 ↵ |
| | Description | Setting OUT1 switching time to 400 ms. |
| Remarks | | — |

| @GWC / @SWC | | Wipe color |
|--------------------|-------------|--|
| Getting | Command | @GWC, ch <input type="checkbox"/> |
| | Response | @GWC, ch, red, green, blue <input type="checkbox"/> |
| Setting | Command | @SWC, ch_1, red_1, green_1, blue_1 (, ch_2, red_2, green_2, blue_2···) <input type="checkbox"/> |
| | Response | @SWC, ch_1, red_1, green_1, blue_1 (, ch_2, red_2, green_2, blue_2···) <input type="checkbox"/> |
| Parameter | | <p>ch: Output channel 1 = OUT1 to 4 = OUT4</p> <p>ch_1-4: Output channel 0 = All outputs, 1 = OUT1 to 4 = OUT4</p> <p>red / red_1-4 : Wipe color (Red) green / green_1-4 : Wipe color (Green) blue / blue_1-4 : Wipe color (Blue) 0 to 255 [Default] 0 (black)</p> |
| Getting example | Command | @GWC,1 <input type="checkbox"/> |
| | Response | @GWC,1,255,255,255 <input type="checkbox"/> |
| | Description | Getting the set wipe color of OUT1. RGB: 255 (white) |
| Setting example | Command | @SWC,1,255,255,255 <input type="checkbox"/> |
| | Response | @SWC,1,255,255,255 <input type="checkbox"/> |
| | Description | Setting the wipe colors (RGB) of OUT1 to "255" (white). |
| Remarks | | — |

| @GVO / @SVO | | HDMI / HDBaseT output |
|-----------------|-------------|---|
| Getting | Command | @GVO ↵ |
| | Response | @GVO, out_1A, out_1B, out_2A, out2B, ..., out_4A, out_4B ↵ |
| Setting | Command | @SVO, ch_1, out_1A, out_1B (, ch_2, out_2A, out_2B···) ↵ |
| | Response | @SVO, ch_1, out_1A, out_1B (, ch_2, out_2A, out_2B···) ↵ |
| Parameter | | <p>out_1A-4A: HDMI (OUT A) output video out_1B-4B: HDBaseT (OUT B) output video 0 = Not output, 1 = Output [Default]: HDMI output signal is output from HDMI output connector, HDBaseT signal is not output from HDBaseT output connector (All output channels)</p> <p>* The MSD cannot output signals from HDMI connector and HDBaseT connector simultaneously. Ensure to set only one connector to output signal</p> |
| | | <p>ch_1-4: Output channel 0 = All outputs, 1 = OUT1 to 4 = OUT4</p> |
| Getting example | Command | @GVO ↵ |
| | Response | @GVO,1,0,1,0,0,1,0,1 ↵ |
| | Description | <p>Getting the video output connectors. OUT1 and OUT2: The HDMI output connectors output video while the HDBaseT output connectors do not output video. OUT3 and OUT4: The HDMI output connectors do not output video while the HDBaseT output connectors output video.</p> |
| Setting example | Command | @SVO,1,1,0 ↵ |
| | Response | @SVO,1,1,0 ↵ |
| | Description | <p>Setting video output connector. OUT1: The HDMI output connector outputs video and the HDBaseT output connector does not output video.</p> |
| Remarks | | An error occurs if the same parameter is issued to both HDMI output connector and HDBaseT output connector. |

| @GEN / @SEN | | HDCP output |
|--------------------|-------------|---|
| Getting | Command | @GEN |
| | Response | @GEN, hdcp_1, hdcp_2, hdcp_3, hdcp_4 |
| Setting | Command | @SEN, ch_1, hdcp_1 (, ch_2, hdcp_2····) |
| | Response | @SEN, ch_1, hdcp_1 (, ch_2, hdcp_2····) |
| Parameter | | hdcp_1-4: HDCP output 0 = HDCP is encrypted only if input signal is with HDCP, 1 = HDCP is always encrypted. [Default], 2 = HDCP is not encrypted. |
| | | ch_1-4: Output channel 0 = All outputs, 1 = OUT1 to 4 = OUT4 |
| Getting example | Command | @GEN |
| | Response | @GEN,1,1,1,0 |
| | Description | Getting the set HDCP output. OUT4: HDCP is encrypted only if input signal is with HDCP. Other output channels: HDCP is always encrypted. |
| Setting example | Command | @SEN,1,1 |
| | Response | @SEN,1,1 |
| | Description | Setting OUT1 to "1" (HDCP is always encrypted). |
| Remarks | | — |

| @GHR / @SHR | | The number of HDCP retries |
|--------------------|-------------|---|
| Getting | Command | @GHR |
| | Response | @GHR, retry_1, retry_2, retry_3, retry_4 |
| Setting | Command | @SHR, ch_1, retry_1 (, ch_2, retry_2····) |
| | Response | @SHR, ch_1, retry_1 (, ch_2, retry_2····) |
| Parameter | | retry_1-4: The number of retries -1 = Retry until succeed [Default], 0 = Not retry, 1 to 100 = Retry for the desired number of retries |
| | | ch_1-4: Output channel 0 = All outputs, 1 = OUT1 to 4 = OUT4 |
| Getting example | Command | @GHR |
| | Response | @GHR,-1,-1,-1,10 |
| | Description | Getting the set number of HDCP retries. OUT4: Retry for up to 10 times. Other output channels: continue to retry until succeed. |
| Setting example | Command | @SHR,4,10 |
| | Response | @SHR,4,10 |
| | Description | Setting OUT4 to retry for up to 10 times. |
| Remarks | | — |

| @GDC / @SDC | | Deep Color |
|--------------------|-------------|--|
| Getting | Command | @GDC |
| | Response | @GDC, color_1, color_2, color_3, color_4 |
| Setting | Command | @SDC, ch_1, color_1 (, ch_2, color_2···) |
| | Response | @SDC, ch_1, color_1 (, ch_2, color_2···) |
| Parameter | | color_1-4: Color depth 0 = 24-BIT COLOR [Default], 1 = 30-BIT COLOR |
| | | ch_1-4: Output channel 0 = All outputs, 1 = OUT1 to 4 = OUT4 |
| Getting example | Command | @GDC |
| | Response | @GDC,1,1,0,1,1,1,1 |
| | Description | Getting the set color depth. OUT3: 24-BIT COLOR, Other output channels: 30-BIT COLOR |
| Setting example | Command | @SDC,1,0 |
| | Response | @SDC,1,0 |
| | Description | Setting OUT1 deep color to 24-BIT COLOR. |
| Remarks | | — |

| @GCE / @SCE | | CEC connection |
|--------------------|-------------|---|
| Getting | Command | @GCE |
| | Response | @GCE, connect_1, connect_2, connect_3, connect_4 |
| Setting | Command | @SCE, ch_1, connect_1 (, ch_2, connect_2···) |
| | Response | @SCE, ch_1, connect_1 (, ch_2, connect_2···) |
| Parameter | | connect_1-4: CEC connection 0 = Not connected [Default], 1 = Selected video input channel, 2 = Input channel1, 3 = Input channel2, 4 = Input channel3, 5 = Input channel4, 6 = Input channel5, 7 = Input channel8 |
| | | ch_1-4: Output channel 0 = All outputs, 1 = OUT1 to 4 = OUT4 |
| Getting example | Command | @GCE |
| | Response | @GCE,4,0,0,0 |
| | Description | Getting the set CEC connection. OUT1: connecting to input channel3, Other output channels: not connected. |
| Setting example | Command | @SCE,1,4 |
| | Response | @SCE,1,4 |
| | Description | Setting OUT1 CEC connection to Input channel3. |
| Remarks | | — |

| @HAU | | HDCP re-encryption |
|-----------------|-------------|---|
| Setting | Command | @HAU, ch_1 (, ch_2···) ↵ |
| | Response | @HAU, ch_1 (, ch_2···) ↵ |
| Parameter | | ch_1-4: Output channel 0 = All outputs, 1 = OUT1 to 4 = OUT4 |
| Setting example | Command | @HAU,1 ↵ |
| | Response | @HAU,1 ↵ |
| | Description | Setting OUT1 to re-encrypt HDCP. |
| Remarks | | — |

| @GAU / @SAU | | Priority of input channel automatic switching (OFF to ON) |
|--------------------|-------------|--|
| Getting | Command | @GAU, out ↵ |
| | Response | @GAU, out, in1_priority, in2_priority, in3_priority, in4_priority, ···, in8_priority ↵ |
| Setting | Command | @SAU, out_1, in1_priority, in2_priority···, in8_priority (, out_2, in1_priority···) ↵ |
| | Response | @SAU, out_1, in1_priority, in2_priority···, in8_priority (, out_2, in1_priority···) ↵ |
| Parameter | | out, out_1-4: Output channel 0 = All outputs, 1 = OUT1 to 4 = OUT4 in1_priority-in8_priority: Priority 0 = OFF, 1 = priority (high) to 8 = priority (low) |
| Getting example | Command | @GAU,1 ↵ |
| | Response | @GAU,1,1,2,3,4,5,6,7,8 ↵ |
| | Description | Getting the set priority of OUT1's automatic switching. IN1>IN2>···>IN8. |
| Setting example | Command | @SAU,1,8,7,6,5,4,3,2,1 ↵ |
| | Response | @SAU,1,8,7,6,5,4,3,2,1 ↵ |
| | Description | Setting the priority of OUT1's automatic switching to IN8>IN7>···>IN1. |
| Remarks | | — |

| @GOF / @SOF | | Priority of input channel automatic switching (ON to OFF) |
|--------------------|-------------|---|
| Getting | Command | @GOF, out [↵] |
| | Response | @GOF, out, in1_priority, in2_priority, in3_priority, in4_priority, ···, in8_priority [↵] |
| Setting | Command | @SOF, out_1, in1_priority, in2_priority···, in8_priority (, out_2, in1_priority···) [↵] |
| | Response | @SOF, out_1, in1_priority, in2_priority···, in8_priority (, out_2, in1_priority···) [↵] |
| Parameter | | out, out_1-4: Output channel 0 = All outputs, 1 = OUT1 to 4 = OUT4 |
| | | in1_priority-in8_priority: Priority 0 = OFF, 1 = priority (high) to 8 = priority (low) |
| Getting example | Command | @GOF,1 [↵] |
| | Response | @GOF,1,1,2,3,4,5,6,7,8 [↵] |
| | Description | Getting the set priority of OUT1's automatic switching. IN1>IN2>···>IN8 |
| Setting example | Command | @SOF,1,8,7,6,5,4,3,2,1 [↵] |
| | Response | @SOF,1,8,7,6,5,4,3,2,1 [↵] |
| | Description | Setting the priority of OUT1's automatic switching to IN8>IN7>···>IN1. |
| Remarks | | — |

| @GMT / @SMT | | Masking time after automatic switching of input channel |
|--------------------|-------------|--|
| Getting | Command | @GMT [↵] |
| | Response | @GMT, time_1, time_2, time_3, time_4 [↵] |
| Setting | Command | @SMT, ch_1, time_1 (, ch_2, time_2···) [↵] |
| | Response | @SMT, ch_1, time_1 (, ch_2, time_2···) [↵] |
| Parameter | | time_1-4 : Masking time 0 = 0 sec. to 999999 = 999.999 sec. [Default] 0 sec. |
| | | ch_1-4: Output channel 0 = All outputs, 1 = OUT1 to 4 = OUT4 |
| Getting example | Command | @GMT [↵] |
| | Response | @GMT,2000,2000,10000,10000 [↵] |
| | Description | Getting the set masking time after automatic switching of input channel. OUT1 and OUT2: 2000 ms (2 sec.), OUT3 and OUT4: 10000 ms (10 sec.) |
| Setting example | Command | @SMT,1,2000,2,2000,3,10000,4,10000 [↵] |
| | Response | @SMT,1,2000,2,2000,3,10000,4,10000 [↵] |
| | Description | Setting the masking time to 2000 ms. (2 sec.) for OUT1 and OUT2, 10000 ms. (10 sec.) for OUT3 and OUT4. |
| Remarks | | — |

| @GAD / @SAD | | Channel switching mode for input channel automatic switching |
|--------------------|-------------|--|
| Getting | Command | @GAD |
| | Response | @GAD, mode_1, mode_2, mode_3, mode_4 |
| Setting | Command | @SAD, ch_1, mode_1 (, ch_2, mode_2···) |
| | Response | @SAD, ch_1, mode_1 (, ch_2, mode_2···) |
| Parameter | | mode_1-4 : Channel switching mode 0 = VIDEO, 1 = AUDIO, 2 = V&A [Default] |
| | | ch_1-4: Output channel 0 = All outputs, 1 = OUT1 to 4 = OUT4 |
| Getting example | Command | @GAD |
| | Response | @GAD,2,2,1,1 |
| | Description | Getting the set channel switching mode to: OUT1 and OUT2: V&A, OUT3 and OUT4: AUDIO |
| Setting example | Command | @SAD,1,2,2,2,3,0,4,0 |
| | Response | @SAD,1,2,2,2,3,0,4,0 |
| | Description | Setting the channel switching mode to: OUT1 and OUT2: V&A, OUT3 and OUT4: VIDEO |
| Remarks | | — |

| @GOA / @SOA | | HDBaseT output long reach mode |
|--------------------|-------------|--|
| Getting | Command | @GOA, ch |
| | Response | @GOA, ch, mode |
| Setting | Command | @SOA, ch_1, mode_1 (, ch_2, mode_2···) |
| | Response | @SOA, ch_1, mode_1 (, ch_2, mode_2···) |
| Parameter | | mode_1-4: Setting mode 0 = long reach mode OFF [Default], 1 = long reach mode ON |
| | | ch_1-4: Output channel 0 = All outputs, 1 = OUT1B to 4 = OUT4B |
| Getting example | Command | @GOA,1 |
| | Response | @GOA,1,0 |
| | Description | Getting long reach mode setting of OUT1B. OUT1B: Long reach mode is set to OFF |
| Setting example | Command | @SOA,1,1 |
| | Response | @SOA,1,1 |
| | Description | Setting long reach mode of OUT1B to ON. |
| Remarks | | If this menu is set to “ON”, resolutions up to 1080p (24 bit) are supported. If it exceeds 1080p (24 bit), signals cannot be received. |

3.3.10 Audio

| @GSL / @SSL | | Audio output level |
|--------------------|-------------|---|
| Getting | Command | @GSL |
| | Response | @GSL, level_1, level_2, level_3, level_4 |
| Setting | Command | @SSL, ch_1, level_1 (, ch_2, level_2···) |
| | Response | @SSL, ch_1, level_1 (, ch_2, level_2···) |
| Parameter | | level_1-4: Audio output level -60 to 10 [Default] 0 |
| | | ch_1-4: Output channel 0 = All outputs, 1 = OUT1 to 4 = OUT4 |
| Getting example | Command | @GSL |
| | Response | @GSL,-4,-4,0,0 |
| | Description | Getting the set audio output level. OUT1 and OUT2: -4 dB, OUT3 and OUT4: ±0 dB |
| Setting example | Command | @SSL,1,-4 |
| | Response | @SSL,1,-4 |
| | Description | Setting OUT1 audio output level to -4 dB. |
| Remarks | | If you change the output level while muted, it will be unmuted. |

| @SOL | | Relative value of audio output level |
|-----------------|-------------|---|
| Setting | Command | @SOL, ch_1, updown_1 (, ch_2, updown_2···) |
| | Response | @SOL, ch_1, updown_1 (, ch_2, updown_2···) |
| Parameter | | ch_1-4: Output channel 0 = All outputs, 1 = OUT1 to 4 = OUT4 |
| | | updown_1-4: Relative value setting -70 to 70 |
| | | The specified value is added to the current audio output level. If the total value exceeds the limit value (-60 to +10), the limit value will be applied. |
| Setting example | Command | @SOL,1,-1 |
| | Response | @SOL,1,-1 |
| | Description | Lower 1 dB of audio output level of OUT1. |
| Remarks | | If you change the output level while muted, it will be unmuted. |

| @GOL | | Limit status of audio output level |
|-----------------|-------------|---|
| Getting | Command | @GOL ↵ |
| | Response | @GOL, out_1, out_2, out_3, out_4 ↵ |
| Parameter | | out_1-4: Limit status of audio output level -1 = minimum settable value (-60 dB), 0 = not limit status, 1 = maximum settable value (+10 dB) |
| Getting example | Command | @GOL ↵ |
| | Response | @GOL,1,1,0,0 ↵ |
| | Description | Getting limit status of audio output level. OUT1 to OUT2: maximum settable value OUT3 to OUT4: not reach the limit value |
| Remarks | | — |

| @GAM / @SAM | | Audio output mute | |
|--------------------|-------------|---|--|
| Getting | Command | @GAM ↵ | |
| | Response | @GAM, mute_1, mute_2, mute_3, mute_4 ↵ | |
| Setting | Command | @SAM, ch_1, mute_1 (, ch_2, mute_2···) ↵ | |
| | Response | @SAM, ch_1, mute_1 (, ch_2, mute_2···) ↵ | |
| Parameter | | mute_1-4: Audio output mute 0 = Mute OFF [Default], 1 = Mute ON ch_1-4: Output channel 0 = All outputs, 1 = OUT1 to 4 = OUT4 | |
| Getting example | Command | @GAM ↵ | |
| | Response | @GAM,1,1,0,0 ↵ | |
| | | Description | Getting the set value of audio output mute. OUT1 and OUT2: Mute ON, OUT3 and OUT4: Mute OFF |
| Setting example | Command | @SAM,1,1 ↵ | |
| | Response | @SAM,1,1 ↵ | |
| | Description | Muting OUT1 audio output. | |
| Remarks | | — | |

| @GAS / @SAS | | Selecting audio input |
|-----------------|-------------|---|
| Getting | Command | @GAS ↵ |
| | Response | @GAS, select_1, select_2, select_3, select_4, ..., select_8 ↵ |
| Setting | Command | @SAS, ch_1, select_1 (, ch_2, select_2...) ↵ |
| | Response | @SAS, ch_1, select_1 (, ch_2, select_2...) ↵ |
| Parameter | | select_1-8: Audio input selection 0 = Digital audio [Default], 1 = analog audio 1, 2 = analog audio 2 |
| | | ch_1-8: Input channel 0 = All digital inputs, 1 = IN1 to 8 = IN8 |
| Getting example | Command | @GAS ↵ |
| | Response | @GAS,1,0,0,0,0,0,0,0 ↵ |
| | Description | Getting the set audio input selection. IN1: analog audio IN1 Other input channels: digital audio |
| Setting example | Command | @SAS,3,0 ↵ |
| | Response | @SAS,3,0 ↵ |
| | Description | Setting IN3 audio input to digital audio. |
| Remarks | | — |

| @GSO / @SSO | | Aduio input level |
|--------------------|-------------|---|
| Getting | Command | @GSO |
| | Response | @GSO, level_1, level_2, level_3, level_4, ..., level_8 |
| Setting | Command | @SSO, ch_1, level_1 (, ch_2, level_2····) |
| | Response | @SSO, ch_1, level_1 (, ch_2, level_2····) |
| Parameter | | level_1-8: Audio input level -60 to 0 [Default] 0 ch_1-8: Input channel 0 = All inputs, 1 = IN1 to 8 = IN8 |
| Getting example | Command | @GSO |
| | Response | @GSO,0,0,0,0,-4,0,0,0 |
| | Description | Getting audio input level. IN5: -4 dB, other input channels: ± 0 dB |
| Setting example | Command | @SSO,5,-8 |
| | Response | @SSO,5,-8 |
| | Description | Setting IN5 audio input level to -8 dB. |
| Remarks | | — |

| @SIL | | Relative value of audio input level |
|-----------------|-------------|---|
| Setting | Command | @SIL, ch_1, updown_1 (, ch_2, updown_2····) |
| | Response | @SIL, ch_1, updown_1 (, ch_2, updown_2····) |
| Parameter | | ch_1-8: Input channel 0 = All inputs, 1 = IN1 to 8 = IN8 updown_1-8: Setting relative value -60 to 60 The specified value is added to the current audio input level. If the total value exceeds the limit value (-60 to +0), the limit value will be applied. |
| Setting example | Command | @SIL,1,-1 |
| | Response | @SIL,1,-1 |
| | Description | Lowering IN1 audio input level (1 dB). |
| Remarks | | — |

| @GIL | | Limit status of audio input level |
|-----------------|----------|---|
| Getting | Command | @GIL |
| | Response | @GIL, in_1, in_2, in_3, in_4, ..., in_8 |
| Parameter | | in_1-8: Limit status -1 = minimum settable value (-60 dB), 0 = not limit status, 1 = maximum settable value (± 0 dB) |
| Getting example | Command | @GIL |
| | Response | @GIL,1,0,0,0,0,0,0 |
| Description | | Getting the set limit status of audio input level. IN1: maximum settable value Other input channels: not limit value |
| Remarks | | — |

| @GLO / @SLO | | Output lip sync |
|--------------------|-------------|---|
| Getting | Command | @GLO |
| | Response | @GLO, frame_1, frame_2, frame_3, frame_4 |
| Setting | Command | @SLO, ch_1, frame_1 (, ch_2, frame_2···) |
| | Response | @SLO, ch_1, frame_1 (, ch_2, frame_2···) |
| Parameter | | frame_1-4: Output lip sync 0 to 8 [Default] 0 |
| | | ch_1-4: Output channel 0 = All outputs, 1 = OUT1 to 4 = OUT4 |
| Getting example | Command | @GLO |
| | Response | @GLO,0,0,2,2 |
| | Description | Getting the set lip sync of the output side. OUT1 and OUT2: 0 frame, OUT3 and OUT4: 2 frames |
| Setting example | Command | @SLO,1,2 |
| | Response | @SLO,1,2 |
| | Description | Setting the OUT1 lip sync to 2 frames. |
| Remarks | | — |

| @GLY / @SLY | | Input lip sync |
|--------------------|-------------|---|
| Getting | Command | @GLY |
| | Response | @GLY, frame_1, frame_2, frame_3, frame_4, ···, frame_8 |
| Setting | Command | @SLY, ch_1, frame_1 (, ch_2, frame_2···) |
| | Response | @SLY, ch_1, frame_1 (, ch_2, frame_2···) |
| Parameter | | frame_1-8: Input lip sync 0 to 8 [Default] 0 |
| | | ch_1-8: Input channel 0 = All inputs, 1 = IN1 to 8 = IN8 |
| Getting example | Command | @GLY |
| | Response | @GLY,0,0,0,2,0,0,0,0 |
| | Description | Getting the set lip sync of input side. IN4: 2 frames, other input channels: 0 frame |
| Setting example | Command | @SLY,4,2 |
| | Response | @SLY,4,2 |
| | Description | Setting the IN4 lip sync to 2 frames. |
| Remarks | | — |

| @GSF / @SSF | | Sampling frequency |
|--------------------|-------------|--|
| Getting | Command | @GSF |
| | Response | @GSF, frequency_1, frequency_2, frequency_3, frequency_4 |
| Setting | Command | @SSF, ch_1, frequency_1 (, ch_2, frequency_2···) |
| | Response | @SSF, ch_1, frequency_1 (, ch_2, frequency_2···) |
| Parameter | | frequency_1-4: Sampling frequency 0 = AUTO [Default], 1 = 32 kHz, 2 = 44.1 kHz, 3 = 48 kHz, 4 = 88.2 kHz, 5 = 96 kHz, 6 = 192 kHz |
| | | ch_1-4: Output channel 0 = All outputs, 1 = OUT1 to 4 = OUT4 |
| Getting example | Command | @GSF |
| | Response | @GSF,0,0,2,2 |
| | Description | Getting sampling frequency settings. OUT1 and OUT2: AUTO, OUT3 and OUT4: 32 kHz |
| Setting example | Command | @SSF,1,3 |
| | Response | @SSF,1,3 |
| | Description | Setting OUT1 sampling frequency to 48 kHz. |
| Remarks | | — |

| @GFD | | Actual sampling frequency |
|-----------------|-------------|---|
| Getting | Command | @GFD |
| | Response | @GFD, frequency_1, frequency_2, frequency_3, frequency_4 |
| Parameter | | frequency_1-4: Sampling frequency 1 = 32 kHz, 2 = 44.1 kHz, 3 = 48 kHz, 4 = 88.2 kHz, 5 = 96 kHz, 6 = 192 kHz |
| Getting example | Command | @GFD |
| | Response | @GFD,5,5,3,3 |
| | Description | Getting the actual sampling frequency. OUT1 and OUT2: 96 kHz, OUT3 and OUT4: 48 kHz |
| Remarks | | “@GSF / @SSF Sampling frequency” is set to “AUTO”, the sampling frequency that is output actually is returned. If it is set to value other than “AUTO”, the set sampling frequency is returned. |

| @GCS / @SCS | | Analog audio output |
|--------------------|-------------|---|
| Getting | Command | @GCS |
| | Response | @GCS, channel |
| Setting | Command | @SCS, channel |
| | Response | @SCS, channel |
| Parameter | | channel: Output channel 1 = OUT1 [Default] to 4 = OUT4 |
| Getting example | Command | @GCS |
| | Response | @GCS,2 |
| | Description | Getting the analog audio output setting. Distributing audio from the OUT2. |
| Setting example | Command | @SCS,1 |
| | Response | @SCS,1 |
| | Description | Setting the analog audio output to OUT 1. |
| Remarks | | — |









| @GMD / @SMD | | Multi channel audio output |
|--------------------|-------------|---|
| Getting | Command | @GMD |
| | Response | @GMD, out_1, out_2, out_3, out_4 |
| Setting | Command | @SMD, ch_1, out_1 (, ch_2, out_2···) |
| | Response | @SMD, ch_1, out_1 (, ch_2, out_2···) |
| Parameter | | out_1-4: Multi channel audio output 0 = CH1 / CH2 STEREO, 1 = CH3 / CH4 STEREO, 2 = CH5 / CH6 STEREO, 3 = CH7 / CH8 STEREO, 4 = CH1 / CH2 MONO, 5 = CH3 / CH4 MONO, 6 = CH5 / CH6 MONO, 7 = CH7 / CH8 MONO, 8 = DOWN MIX [Default] |
| | | ch_1-4: Output channel 0 = All outputs, 1 = OUT1 to 4 = OUT4 |
| Getting example | Command | @GMD |
| | Response | @GMD,4,4,8,8 |
| | Description | Getting the multi channel audio output's setting. OUT1 and OUT2: Outputs monaural audio of CH1 / CH2 OUT3 and OUT4: Outputs downmixed audio. |
| Setting example | Command | @SMD,1,8 |
| | Response | @SMD,1,8 |
| | Description | Setting OUT1 to output downmixed audio. |
| Remarks | | — |

| @GAT / @SAT | | Test tone |
|--------------------|-------------|--|
| Getting | Command | @GAT ↵ |
| | Response | @GAT, tone_1, speaker_1, tone_2, speaker_2, tone_3, speaker_3, tone_4, speaker_4 ↵ |
| Setting | Command | @SAT, ch_1, tone_1, speaker_1 (, ch_2, tone_2, speaker_2···) ↵ |
| | Response | @SAT, ch_1, tone_1, speaker_1 (, ch_2, tone_2, speaker_2···) ↵ |
| Parameter | | <p>tone_1-4: Test tone 0 = OFF [Default], 1 = 1 kHz, 2 = 400 Hz</p> <p>speaker_1-4: Speaker 0 = ALL [Default], 1 = FRONT L/R, 2 = REAR L/R, 3 = REAR L/R CENTER, 4 = FRONT LEFT, 5 = FRONT RIGHT, 6 = LOW FREQUENCY EFFECT, 7 = FRONT CENTER, 8 = REAR LEFT, 9 = REAR RIGHT, 10 = REAR LEFT CENTER, 11 = REAR RIGHT CENTER</p> <p>ch_1-4: Output channel 0 = All outputs, 1 = OUT1 to 4 = OUT4</p> |
| Getting example | Command | @GAT ↵ |
| | Response | @GAT,2,1,2,1,0,0,0,0 ↵ |
| | Description | Getting the set test tone output. OUT1 and OUT2: Outputs test tone (400 Hz) to FRONT L/R. OUT3 and OUT4: Not output test tone. |
| Setting example | Command | @SAT,1,1,0 ↵ |
| | Response | @SAT,1,1,0 ↵ |
| | Description | Setting OUT1 to output test tone (1k Hz) to all speakers. |
| Remarks | | — |

3.3.11 EDID

| @GED / @SED | | EDID |
|-----------------|-------------|---|
| Getting | Command | @GED ↵ |
| | Response | @GED, edid_1, edid_2, edid_3, edid_4, ..., edid_8 ↵ |
| Setting | Command | @SED, ch_1, edid_1 (, ch_2, edid_2...) ↵ |
| | Response | @SED, ch_1, edid_1 (, ch_2, edid_2...) ↵ |
| Parameter | | edid_1-8: EDID 0 = Built-in EDID [Default], 1 = OUT1 MONITOR, 2 = OUT2 MONITOR, 3 = OUT3 MONITOR, 4 = OUT4 MONITOR, 101 to 108 = COPY DATA 1 to COPY DATA 8 |
| | | ch_1-8: Input channel 0 = All digital inputs, 1 = IN1 to 8 = IN8 |
| Getting example | Command | @GED ↵ |
| | Response | @GED,0,0,0,3,0,0,0,0 ↵ |
| | Description | Getting the set EDID. IN4: EDID of the sink device that is connected to OUT3, other inputs: built-in EDID |
| Setting example | Command | @SED,2,3 ↵ |
| | Response | @SED,2,3 ↵ |
| | Description | Setting IN2: EDID that is read from the sink device connected to OUT3. |
| Remarks | | These commands are only for digital input. IN7 and IN8: If "0" (Analog signal) is selected for " @GIN / @SIN Signal selection of DVI input connector ", "-1" is acquired and the setting cannot be valid. In order to use a copied data, read EDID data from the sink device in " @RME Copying EDID " in advance. |

| @GVF / @SVF | | Input resolution for PC | | | | | | | | | | | | | | | | | | | | | | |
|--------------------------|-------------------------|---|--------------------|--------------------|---------------------|---------------------|---------------------|-------------------------|----------------------|---------------------|---------------------|-----------------------|-----------------------|------------------------|-----------------------|-------------------------|------------------------|------------------------|------------------------|-----------------------|-----------------------|------------------------|--------------------------|--|
| Getting | Command | @GVF | | | | | | | | | | | | | | | | | | | | | | |
| | Response | @GVF, resolution_1, resolution_2, resolution_3, resolution_4, ..., resolution_8 | | | | | | | | | | | | | | | | | | | | | | |
| Setting | Command | @SVF, ch_1, resolution_1 (, ch_2, resolution_2···) | | | | | | | | | | | | | | | | | | | | | | |
| | Response | @SVF, ch_1, resolution_1 (, ch_2, resolution_2···) | | | | | | | | | | | | | | | | | | | | | | |
| Parameter | | <p>resolution_1-8: Input resolution for PC</p> <table border="0"> <tr> <td>0 = SVGA(800x600),</td> <td>1 = XGA(1024x768),</td> </tr> <tr> <td>2 = 720p(1280x720),</td> <td>3 = WXGA(1280x768),</td> </tr> <tr> <td>4 = WXGA(1280x800),</td> <td>5 = Quad-VGA(1280x960),</td> </tr> <tr> <td>6 = SXGA(1280x1024),</td> <td>7 = WXGA(1360x768),</td> </tr> <tr> <td>8 = WXGA(1366x768),</td> <td>9 = SXGA+(1400x1050),</td> </tr> <tr> <td>10 = WXGA+(1440x900),</td> <td>11 = WXGA++(1600x900),</td> </tr> <tr> <td>12 = UXGA(1600x1200),</td> <td>13 = WSXGA+(1680x1050),</td> </tr> <tr> <td>14 = 1080i(1920x1080),</td> <td>15 = 1080p(1920x1080),</td> </tr> <tr> <td>16 = WUXGA(1920x1200),</td> <td>17 = QWXGA(2048x1152)</td> </tr> <tr> <td>18 = WQHD(2560x1440),</td> <td>19 = WQXGA(2560x1600),</td> </tr> <tr> <td>40 = 2160p@30(3840x2160)</td> <td></td> </tr> </table> <p>[Default] IN1 to IN8: 1080p(1920x1080)</p> | 0 = SVGA(800x600), | 1 = XGA(1024x768), | 2 = 720p(1280x720), | 3 = WXGA(1280x768), | 4 = WXGA(1280x800), | 5 = Quad-VGA(1280x960), | 6 = SXGA(1280x1024), | 7 = WXGA(1360x768), | 8 = WXGA(1366x768), | 9 = SXGA+(1400x1050), | 10 = WXGA+(1440x900), | 11 = WXGA++(1600x900), | 12 = UXGA(1600x1200), | 13 = WSXGA+(1680x1050), | 14 = 1080i(1920x1080), | 15 = 1080p(1920x1080), | 16 = WUXGA(1920x1200), | 17 = QWXGA(2048x1152) | 18 = WQHD(2560x1440), | 19 = WQXGA(2560x1600), | 40 = 2160p@30(3840x2160) | |
| 0 = SVGA(800x600), | 1 = XGA(1024x768), | | | | | | | | | | | | | | | | | | | | | | | |
| 2 = 720p(1280x720), | 3 = WXGA(1280x768), | | | | | | | | | | | | | | | | | | | | | | | |
| 4 = WXGA(1280x800), | 5 = Quad-VGA(1280x960), | | | | | | | | | | | | | | | | | | | | | | | |
| 6 = SXGA(1280x1024), | 7 = WXGA(1360x768), | | | | | | | | | | | | | | | | | | | | | | | |
| 8 = WXGA(1366x768), | 9 = SXGA+(1400x1050), | | | | | | | | | | | | | | | | | | | | | | | |
| 10 = WXGA+(1440x900), | 11 = WXGA++(1600x900), | | | | | | | | | | | | | | | | | | | | | | | |
| 12 = UXGA(1600x1200), | 13 = WSXGA+(1680x1050), | | | | | | | | | | | | | | | | | | | | | | | |
| 14 = 1080i(1920x1080), | 15 = 1080p(1920x1080), | | | | | | | | | | | | | | | | | | | | | | | |
| 16 = WUXGA(1920x1200), | 17 = QWXGA(2048x1152) | | | | | | | | | | | | | | | | | | | | | | | |
| 18 = WQHD(2560x1440), | 19 = WQXGA(2560x1600), | | | | | | | | | | | | | | | | | | | | | | | |
| 40 = 2160p@30(3840x2160) | | | | | | | | | | | | | | | | | | | | | | | | |
| | | <p>ch_1-8: Input channel</p> <p>0 = All inputs, 1 = IN1 to 8 = IN8</p> | | | | | | | | | | | | | | | | | | | | | | |
| Getting example | Command | @GVF | | | | | | | | | | | | | | | | | | | | | | |
| | Response | @GVF,6,6,9,6,6,6,6,6 | | | | | | | | | | | | | | | | | | | | | | |
| | Description | Getting the set input resolution for PC. IN3: SXGA+(1400x1050), other input channels: SXGA(1280x1024) | | | | | | | | | | | | | | | | | | | | | | |
| Setting example | Command | @SVF,0,12 | | | | | | | | | | | | | | | | | | | | | | |
| | Response | @SVF,0,12 | | | | | | | | | | | | | | | | | | | | | | |
| | Description | Setting EDID of all input channels to UXGA (1600x1200). | | | | | | | | | | | | | | | | | | | | | | |
| Remarks | | — | | | | | | | | | | | | | | | | | | | | | | |

| @GHF / @SHF | | Input resolution for AV devices |
|--------------------|-------------|--|
| Getting | Command | @GHF  |
| | Response | @GHF, resolution_1, resolution_2, resolution_3, resolution_4, ..., resolution_8  |
| Setting | Command | @SHF, ch_1, resolution_1 (, ch_2, resolution_2...)  |
| | Response | @SHF, ch_1, resolution_1 (, ch_2, resolution_2...)  |
| Parameter | | resolution_1-8: Input resolution for AV devices 0 = UNUSED, 1 = 480p, 2 = 720p, 3 = 1080i, 4 = 1080p, 5 = AUTO [Default], 6 = 2160@30, 9 = 4096x2160@30 |
| | | ch_1-8: Input channel 0 = All digital inputs, 1 = IN1 to 8 = IN8 |
| Getting example | Command | @GHF  |
| | Response | @GHF,5,5,5,4,5,5,5,5  |
| | Description | Getting the set input resolution for AV devices. IN4: 1080p, other inputs: AUTO |
| Setting example | Command | @SHF,0,4  |
| | Response | @SHF,0,4  |
| | Description | Setting EDIDs of all input channels to 1080p. |
| Remarks | | These commands are only for digital input. IN7 and IN8 are available only when "1" (Digital signal) is selected for " @GIN / @SIN Signal selection of DVI input connector ". If "0" (Analog signal) is selected, "-1" is returned. |

| @GDI / @SDI | | Deep Color input |
|-----------------|-------------|--|
| Getting | Command | @GDI [↵] |
| | Response | @GDI, color_1, color_2, color_3, color_4, ..., color_8 [↵] |
| Setting | Command | @SDI, ch_1, color_1 (, ch_2, color_2···) [↵] |
| | Response | @SDI, ch_1, color_1 (, ch_2, color_2···) [↵] |
| Parameter | | color_1-8: Color depth 0 = 24-BIT COLOR [Default], 1 = 30-BIT COLOR |
| | | ch_1-8: Input channel 0 = All digital inputs, 1 = IN1 to 8 = IN8 |
| Getting example | Command | @GDI [↵] |
| | Response | @GDI,1,1,1,0,1,1,1,1 [↵] |
| | Description | Getting the set color depth. IN4: 24-BIT COLOR, Other input channels: 30-BIT COLOR |
| Setting example | Command | @SDI,4,0 [↵] |
| | Response | @SDI,4,0 [↵] |
| | Description | Setting the set IN4 color depth to 24-BIT COLOR. |
| Remarks | | These commands are only for digital input. IN7 and IN8 are available only when "1" (Digital signal) is selected for " @GIN / @SIN Signal selection of DVI input connector ". If "0" (Analog signal) is selected, "-1" is returned. |

| @GAF / @SAF | | Audio format | | | | | | | | | | | | | | | | |
|--------------------|---|---|--------------|----------------------------------|-----|--|---------------|----------------------------------|-----|--|----------------|----------------------------------|-----|---------------------------------------|--------|---|--------------|---|
| Getting | Command | @GAF, ch [↵] | | | | | | | | | | | | | | | | |
| | Response | @GAF, ch, format_1, frequency_1 (, format_2, frequency_2···) [↵] | | | | | | | | | | | | | | | | |
| Setting | Command | @SAF, ch, format_1, frequency_1 (, format_2, frequency_2···) [↵] | | | | | | | | | | | | | | | | |
| | Response | @SAF, ch, format_1, frequency_1 (, format_2, frequency_2···) [↵] | | | | | | | | | | | | | | | | |
| Parameter | | <p>ch: Input channel 0 = All digital inputs (for setting only), 1 = IN1 to 8 = IN8</p> <p>format_1-8: Audio format 0 = PCM, 1 = Dolby Digital, 2 = AAC, 3 = Dolby Digital+, 4 = DTS, 5 = DTS-HD, 6 = Dolby TrueHD [Default] only PCM can be output</p> <p>frequency_1-8: Maximum sampling frequency 0 = Not output, 1 = 32 kHz, 2 = 44.1 kHz, 3 = 48 kHz, 4 = 88.2 kHz, 5 = 96 kHz, 6 = 176.4 kHz, 7 = 192 kHz [Default] DTS-HD: 192 kHz, Dolby TrueHD: 96 kHz, other formats: 48 kHz</p> <p>Maximum settable sampling frequency depends on the audio format.</p> <table border="1"> <thead> <tr> <th>Audio format</th> <th>Maximum sampling frequency (kHz)</th> </tr> </thead> <tbody> <tr> <td>PCM</td> <td>32 / 44.1 / 48 / 88.2 / 96 / 176.4 / 192</td> </tr> <tr> <td>Dolby Digital</td> <td>Output disabled / 32 / 44.1 / 48</td> </tr> <tr> <td>AAC</td> <td>Output disabled / 32 / 44.1 / 48 / 88.2 / 96</td> </tr> <tr> <td>Dolby Digital+</td> <td>Output disabled / 32 / 44.1 / 48</td> </tr> <tr> <td>DTS</td> <td>Output disabled / 32 / 44.1 / 48 / 96</td> </tr> <tr> <td>DTS-HD</td> <td>Output disabled / 44.1 / 48 / 88.2 / 96 / 176.4 / 192</td> </tr> <tr> <td>Dolby TrueHD</td> <td>Output disabled / 44.1 / 48 / 88.2 / 96 / 176.4 / 192</td> </tr> </tbody> </table> <p>Getting commands: the set audio formats and maximum sampling frequency is returned. Setting commands: send the desired audio formats and the maximum sampling frequencies. Other audio formats is set to "0" (Output disabled) for the maximum sampling frequency. You do not need to specify "0" parameter normally. PCM is always enabled, you can skip this menu unless you need to change the sampling frequency.</p> | Audio format | Maximum sampling frequency (kHz) | PCM | 32 / 44.1 / 48 / 88.2 / 96 / 176.4 / 192 | Dolby Digital | Output disabled / 32 / 44.1 / 48 | AAC | Output disabled / 32 / 44.1 / 48 / 88.2 / 96 | Dolby Digital+ | Output disabled / 32 / 44.1 / 48 | DTS | Output disabled / 32 / 44.1 / 48 / 96 | DTS-HD | Output disabled / 44.1 / 48 / 88.2 / 96 / 176.4 / 192 | Dolby TrueHD | Output disabled / 44.1 / 48 / 88.2 / 96 / 176.4 / 192 |
| Audio format | Maximum sampling frequency (kHz) | | | | | | | | | | | | | | | | | |
| PCM | 32 / 44.1 / 48 / 88.2 / 96 / 176.4 / 192 | | | | | | | | | | | | | | | | | |
| Dolby Digital | Output disabled / 32 / 44.1 / 48 | | | | | | | | | | | | | | | | | |
| AAC | Output disabled / 32 / 44.1 / 48 / 88.2 / 96 | | | | | | | | | | | | | | | | | |
| Dolby Digital+ | Output disabled / 32 / 44.1 / 48 | | | | | | | | | | | | | | | | | |
| DTS | Output disabled / 32 / 44.1 / 48 / 96 | | | | | | | | | | | | | | | | | |
| DTS-HD | Output disabled / 44.1 / 48 / 88.2 / 96 / 176.4 / 192 | | | | | | | | | | | | | | | | | |
| Dolby TrueHD | Output disabled / 44.1 / 48 / 88.2 / 96 / 176.4 / 192 | | | | | | | | | | | | | | | | | |
| Getting example | Command | @GAF,1 [↵] | | | | | | | | | | | | | | | | |
| | Response | @GAF,1,0,7 [↵] | | | | | | | | | | | | | | | | |
| | Description | Getting the set audio formats for IN1. Up to 192 kHz of PCM. | | | | | | | | | | | | | | | | |
| Setting example | Command | @SAF,2,4,3 [↵] | | | | | | | | | | | | | | | | |
| | Response | @SAF,2,4,3 [↵] | | | | | | | | | | | | | | | | |
| | Description | Enabling IN2 to output PCM and DTS up to 48 kHz (PCM's sampling frequency is not changed). | | | | | | | | | | | | | | | | |
| Remarks | | <p>These commands are only for digital input.</p> <p>IN7 and IN8 are available only when "1" (Digital signal) is selected for "@GIN / @SIN Signal selection of DVI input connector". If "0" (Analog signal) is selected, "-1" is returned.</p> | | | | | | | | | | | | | | | | |

| @GSP / @SSP | | The number of speakers | | | | | | | | | | | | | | | | | | | | | | | | | | | | | | | | | | | | | | | | | | | | | | | | | | | | | | | | | | | | | | | | | | | | | | | | | | | | | | | | | | | | | | | | | | | | | | | | | | | | | | | | | | | | | | | | | | | | | | | |
|---|--|--|--------|---------|-----|-----|-----|-----|-----|-----|-----|--|--|--|---|---|---|---|---|---|---|---|---|---|----|---|-----|-----|----|-----|-----|-----|-----|-----|-----|-----|-----|---|----|-----|-----|-----|-----|-----|-----|-----|-----|-----|-----|---|----|----|-----|-----|-----|-----|-----|-----|-----|-----|-----|---|----|----|----|-----|-----|-----|-----|-----|-----|-----|-----|---|----|----|-----|----|-----|-----|-----|-----|-----|-----|-----|---|----|----|----|----|-----|-----|-----|-----|-----|-----|-----|---|----|----|----|----|----|-----|-----|-----|-----|-----|-----|---|----|----|----|----|-----|-----|----|-----|-----|-----|-----|
| Getting | Command | @GSP, ch <input type="checkbox"/> | | | | | | | | | | | | | | | | | | | | | | | | | | | | | | | | | | | | | | | | | | | | | | | | | | | | | | | | | | | | | | | | | | | | | | | | | | | | | | | | | | | | | | | | | | | | | | | | | | | | | | | | | | | | | | | | | | | | | | | |
| | Response | @GSP, ch, number, speaker_1 (, speaker_2····) <input type="checkbox"/> | | | | | | | | | | | | | | | | | | | | | | | | | | | | | | | | | | | | | | | | | | | | | | | | | | | | | | | | | | | | | | | | | | | | | | | | | | | | | | | | | | | | | | | | | | | | | | | | | | | | | | | | | | | | | | | | | | | | | | | |
| Setting | Command | @SSP, ch, number (, speaker_1, speaker_2····) <input type="checkbox"/> | | | | | | | | | | | | | | | | | | | | | | | | | | | | | | | | | | | | | | | | | | | | | | | | | | | | | | | | | | | | | | | | | | | | | | | | | | | | | | | | | | | | | | | | | | | | | | | | | | | | | | | | | | | | | | | | | | | | | | | |
| | Response | @SSP, ch, number (, speaker_1, speaker_2····) <input type="checkbox"/> | | | | | | | | | | | | | | | | | | | | | | | | | | | | | | | | | | | | | | | | | | | | | | | | | | | | | | | | | | | | | | | | | | | | | | | | | | | | | | | | | | | | | | | | | | | | | | | | | | | | | | | | | | | | | | | | | | | | | | | |
| Parameter | ch: Input channel 0 = All digital inputs (for setting only), 1 = IN1 to 8 = IN8 | | | | | | | | | | | | | | | | | | | | | | | | | | | | | | | | | | | | | | | | | | | | | | | | | | | | | | | | | | | | | | | | | | | | | | | | | | | | | | | | | | | | | | | | | | | | | | | | | | | | | | | | | | | | | | | | | | | | | | | | |
| | number: The number of speakers 1 to 8 [Default] 2 | | | | | | | | | | | | | | | | | | | | | | | | | | | | | | | | | | | | | | | | | | | | | | | | | | | | | | | | | | | | | | | | | | | | | | | | | | | | | | | | | | | | | | | | | | | | | | | | | | | | | | | | | | | | | | | | | | | | | | | | |
| speaker_1-8: Speaker configuration 0 = Front Left / Right [Default], 1 = Low Frequency Effect, 2 = Front Center, 3 = Rear Left / Right, 4 = Rear Center, 5 = Front Left / Right Center, 6 = Rear Left / Right Center, 7 = Front Left / Right Wide, 8 = Front Left / Right High, 9 = Top Center, 10 = Front Center High | | | | | | | | | | | | | | | | | | | | | | | | | | | | | | | | | | | | | | | | | | | | | | | | | | | | | | | | | | | | | | | | | | | | | | | | | | | | | | | | | | | | | | | | | | | | | | | | | | | | | | | | | | | | | | | | | | | | | | | | | |
| Getting commands: the number of speakers and which speakers will be used is returned. | | | | | | | | | | | | | | | | | | | | | | | | | | | | | | | | | | | | | | | | | | | | | | | | | | | | | | | | | | | | | | | | | | | | | | | | | | | | | | | | | | | | | | | | | | | | | | | | | | | | | | | | | | | | | | | | | | | | | | | | | |
| Setting commands: if you do not specify the speaker configuration, the following configuration will be applied depending on the set number of speakers. | | | | | | | | | | | | | | | | | | | | | | | | | | | | | | | | | | | | | | | | | | | | | | | | | | | | | | | | | | | | | | | | | | | | | | | | | | | | | | | | | | | | | | | | | | | | | | | | | | | | | | | | | | | | | | | | | | | | | | | | | |
| <table border="1"> <thead> <tr> <th rowspan="2">number</th> <th colspan="11">speaker</th> </tr> <tr> <th>0</th> <th>1</th> <th>2</th> <th>3</th> <th>4</th> <th>5</th> <th>6</th> <th>7</th> <th>8</th> <th>9</th> <th>10</th> </tr> </thead> <tbody> <tr> <td>1</td> <td>OFF</td> <td>OFF</td> <td>ON</td> <td>OFF</td> <td>OFF</td> <td>OFF</td> <td>OFF</td> <td>OFF</td> <td>OFF</td> <td>OFF</td> <td>OFF</td> </tr> <tr> <td>2</td> <td>ON</td> <td>OFF</td> <td>OFF</td> <td>OFF</td> <td>OFF</td> <td>OFF</td> <td>OFF</td> <td>OFF</td> <td>OFF</td> <td>OFF</td> <td>OFF</td> </tr> <tr> <td>3</td> <td>ON</td> <td>ON</td> <td>OFF</td> <td>OFF</td> <td>OFF</td> <td>OFF</td> <td>OFF</td> <td>OFF</td> <td>OFF</td> <td>OFF</td> <td>OFF</td> </tr> <tr> <td>4</td> <td>ON</td> <td>ON</td> <td>ON</td> <td>OFF</td> <td>OFF</td> <td>OFF</td> <td>OFF</td> <td>OFF</td> <td>OFF</td> <td>OFF</td> <td>OFF</td> </tr> <tr> <td>5</td> <td>ON</td> <td>ON</td> <td>OFF</td> <td>ON</td> <td>OFF</td> <td>OFF</td> <td>OFF</td> <td>OFF</td> <td>OFF</td> <td>OFF</td> <td>OFF</td> </tr> <tr> <td>6</td> <td>ON</td> <td>ON</td> <td>ON</td> <td>ON</td> <td>OFF</td> <td>OFF</td> <td>OFF</td> <td>OFF</td> <td>OFF</td> <td>OFF</td> <td>OFF</td> </tr> <tr> <td>7</td> <td>ON</td> <td>ON</td> <td>ON</td> <td>ON</td> <td>ON</td> <td>OFF</td> <td>OFF</td> <td>OFF</td> <td>OFF</td> <td>OFF</td> <td>OFF</td> </tr> <tr> <td>8</td> <td>ON</td> <td>ON</td> <td>ON</td> <td>ON</td> <td>OFF</td> <td>OFF</td> <td>ON</td> <td>OFF</td> <td>OFF</td> <td>OFF</td> <td>OFF</td> </tr> </tbody> </table> | | | number | speaker | | | | | | | | | | | 0 | 1 | 2 | 3 | 4 | 5 | 6 | 7 | 8 | 9 | 10 | 1 | OFF | OFF | ON | OFF | OFF | OFF | OFF | OFF | OFF | OFF | OFF | 2 | ON | OFF | OFF | OFF | OFF | OFF | OFF | OFF | OFF | OFF | OFF | 3 | ON | ON | OFF | OFF | OFF | OFF | OFF | OFF | OFF | OFF | OFF | 4 | ON | ON | ON | OFF | OFF | OFF | OFF | OFF | OFF | OFF | OFF | 5 | ON | ON | OFF | ON | OFF | OFF | OFF | OFF | OFF | OFF | OFF | 6 | ON | ON | ON | ON | OFF | OFF | OFF | OFF | OFF | OFF | OFF | 7 | ON | ON | ON | ON | ON | OFF | OFF | OFF | OFF | OFF | OFF | 8 | ON | ON | ON | ON | OFF | OFF | ON | OFF | OFF | OFF | OFF |
| number | speaker | | | | | | | | | | | | | | | | | | | | | | | | | | | | | | | | | | | | | | | | | | | | | | | | | | | | | | | | | | | | | | | | | | | | | | | | | | | | | | | | | | | | | | | | | | | | | | | | | | | | | | | | | | | | | | | | | | | | | | | | |
| | 0 | 1 | 2 | 3 | 4 | 5 | 6 | 7 | 8 | 9 | 10 | | | | | | | | | | | | | | | | | | | | | | | | | | | | | | | | | | | | | | | | | | | | | | | | | | | | | | | | | | | | | | | | | | | | | | | | | | | | | | | | | | | | | | | | | | | | | | | | | | | | | | | | | | | | | | |
| 1 | OFF | OFF | ON | OFF | OFF | OFF | OFF | OFF | OFF | OFF | OFF | | | | | | | | | | | | | | | | | | | | | | | | | | | | | | | | | | | | | | | | | | | | | | | | | | | | | | | | | | | | | | | | | | | | | | | | | | | | | | | | | | | | | | | | | | | | | | | | | | | | | | | | | | | | | | |
| 2 | ON | OFF | OFF | OFF | OFF | OFF | OFF | OFF | OFF | OFF | OFF | | | | | | | | | | | | | | | | | | | | | | | | | | | | | | | | | | | | | | | | | | | | | | | | | | | | | | | | | | | | | | | | | | | | | | | | | | | | | | | | | | | | | | | | | | | | | | | | | | | | | | | | | | | | | | |
| 3 | ON | ON | OFF | OFF | OFF | OFF | OFF | OFF | OFF | OFF | OFF | | | | | | | | | | | | | | | | | | | | | | | | | | | | | | | | | | | | | | | | | | | | | | | | | | | | | | | | | | | | | | | | | | | | | | | | | | | | | | | | | | | | | | | | | | | | | | | | | | | | | | | | | | | | | | |
| 4 | ON | ON | ON | OFF | OFF | OFF | OFF | OFF | OFF | OFF | OFF | | | | | | | | | | | | | | | | | | | | | | | | | | | | | | | | | | | | | | | | | | | | | | | | | | | | | | | | | | | | | | | | | | | | | | | | | | | | | | | | | | | | | | | | | | | | | | | | | | | | | | | | | | | | | | |
| 5 | ON | ON | OFF | ON | OFF | OFF | OFF | OFF | OFF | OFF | OFF | | | | | | | | | | | | | | | | | | | | | | | | | | | | | | | | | | | | | | | | | | | | | | | | | | | | | | | | | | | | | | | | | | | | | | | | | | | | | | | | | | | | | | | | | | | | | | | | | | | | | | | | | | | | | | |
| 6 | ON | ON | ON | ON | OFF | OFF | OFF | OFF | OFF | OFF | OFF | | | | | | | | | | | | | | | | | | | | | | | | | | | | | | | | | | | | | | | | | | | | | | | | | | | | | | | | | | | | | | | | | | | | | | | | | | | | | | | | | | | | | | | | | | | | | | | | | | | | | | | | | | | | | | |
| 7 | ON | ON | ON | ON | ON | OFF | OFF | OFF | OFF | OFF | OFF | | | | | | | | | | | | | | | | | | | | | | | | | | | | | | | | | | | | | | | | | | | | | | | | | | | | | | | | | | | | | | | | | | | | | | | | | | | | | | | | | | | | | | | | | | | | | | | | | | | | | | | | | | | | | | |
| 8 | ON | ON | ON | ON | OFF | OFF | ON | OFF | OFF | OFF | OFF | | | | | | | | | | | | | | | | | | | | | | | | | | | | | | | | | | | | | | | | | | | | | | | | | | | | | | | | | | | | | | | | | | | | | | | | | | | | | | | | | | | | | | | | | | | | | | | | | | | | | | | | | | | | | | |
| For speaker configurations: the <i>number</i> and total number of speakers (<i>speaker_1-8</i>) do not match, the <i>number</i> is set automatically based on the setting of <i>speaker_1-8</i> . In case the <i>number</i> exceeds the settable range, an error is returned. | | | | | | | | | | | | | | | | | | | | | | | | | | | | | | | | | | | | | | | | | | | | | | | | | | | | | | | | | | | | | | | | | | | | | | | | | | | | | | | | | | | | | | | | | | | | | | | | | | | | | | | | | | | | | | | | | | | | | | | | | |

| @GSP / @SSP | | The number of speakers (cont'd) |
|--------------------|-------------|--|
| Getting example | Command | @GSP,1 ↵ |
| | Response | @GSP,1,6,0,1,2,3 ↵ |
| | Description | Getting the IN1 speaker configuration. Six speakers (Front Left / Right, Low Frequency Effect, Front Center, Rear Left / Right) are used. |
| Setting example | Command | @SSP,2,8 ↵ |
| | Response | @SSP,2,8 ↵ |
| | Description | Setting IN2 speaker configuration to Front Left / Right, Low Frequency Effect, Front Center, Rear Left / Right, Rear Left / Right Center (eight speakers). Completed normally. |
| Setting example | Command | @SSP,3,8,0,3,5,6,7 ↵ |
| | Response | @ERR,1 ↵ |
| | Description | Setting IN3 speaker configuration to Front Left / Right, Rear Left / Right, Front Left / Right Center, Rear Left / Right Center, Front Left / Right Wide. The number of speakers is 10 which exceeds the settable value, and it causes the error. |
| Remarks | | These commands are only for digital input. IN6 and IN7 are available only when "1" (Digital signal) is selected for " @GIN / @SIN Signal selection of DVI input connector ". If "0" (Analog signal) is selected, "-1" is returned. |

| @RME | | Copying EDID |
|-----------------|-------------|--|
| Setting | Command | @RME, out, number, name ↵ |
| | Response | @RME, out, number, name ↵ |
| Parameter | | out: Connector to be loaded 1 = OUT1 to 4 = OUT4 |
| | | number: Destination COPY DATA number 1 to 8 |
| | | name: COPY DATA name Up to 10 characters using 20 to 7D from ASCII codes. You can skip this setting. In this case, only EDID settings are saved without changing currently saved name. |
| Setting example | Command | @RME,1,1 ↵ |
| | Response | @RME,1,1 ↵ |
| | Description | Loading EDID data of the sink device connected to OUT1 and saving it in COPY DATA 1. |
| Setting example | Command | @RME,3,4,800x600 ↵ |
| | Response | @RME,3,4,800x600 ↵ |
| | Description | Loading EDID data of the sink device connected to OUT3, naming it "800x600" and saving it in COPY DATA 4. |
| Remarks | | @GED / @SED EDID |

3.3.12 RS-232C communication

| @GCT / @SCT | | RS-232C communication |
|-----------------|-------------|--|
| Getting | Command | @GCT ↵ |
| | Response | @GCT, setting_1, setting_2, setting_3 ↵ |
| Setting | Command | @SCT, port, setting ↵ |
| | Response | @SCT, port, setting ↵ |
| Parameter | | setting : Communication setting setting_1 : Communication setting of RS-232C connector setting_2 : Communication setting of HDBaseT input connector IN5 and IN6 setting_3 : Communication setting of HDBaseT output connector OUT1 to OUT4 <ul style="list-style-type: none"> ▪ Baud rate (4800, 9600, 19200, 38400 [bps] [Default] 9600) ▪ Data length (8, 7 [bit] [Default] 8) ▪ Parity check (NONE, EVEN, ODD [Default] NONE) ▪ Stop bit (1, 2 [bit] [Default] 1) For setting values, see the [Table 3.1] . |
| | | port: RS-232C channel 0 = All channels, 1 = RS-232C connector, 2 = IN5 to IN6 3 = OUT1 to OUT4 |
| Getting example | Command | @GCT ↵ |
| | Response | @GCT,24,24,24 ↵ |
| | Description | Getting communication settings of RS-232Cs. All baud rates = 19200 [bps], data bit length = 8 [bit], parity check = NONE, stop bit =1 [bit] |
| Setting example | Command | @SCT,1,24 ↵ |
| | Response | @SCT,1,24 ↵ |
| | Description | Setting RS-232C as follows: baud rate = 19200 [bps], data bit length = 8 [bit], parity check = NONE, stop bit = 1 [bit]. |
| Remarks | | If IP address or RS-232C communication setting is changed, the communication may be disabled. Change the environmental settings based on the MSD settings. |









[Table 3.1] Parameter of RS-232C communication settings

| Value | Communication | | | |
|-------|---------------|---|------|---|
| 0 | 4800 | 8 | NONE | 1 |
| 1 | 4800 | 8 | NONE | 2 |
| 2 | 4800 | 8 | ODD | 1 |
| 3 | 4800 | 8 | ODD | 2 |
| 4 | 4800 | 8 | EVEN | 1 |
| 5 | 4800 | 8 | EVEN | 2 |
| 6 | 4800 | 7 | NONE | 1 |
| 7 | 4800 | 7 | NONE | 2 |
| 8 | 4800 | 7 | ODD | 1 |
| 9 | 4800 | 7 | ODD | 2 |
| 10 | 4800 | 7 | EVEN | 1 |
| 11 | 4800 | 7 | EVEN | 2 |









| Value | Communication | | | |
|-------|---------------|---|------|---|
| 12 | 9600 | 8 | NONE | 1 |
| 13 | 9600 | 8 | NONE | 2 |
| 14 | 9600 | 8 | ODD | 1 |
| 15 | 9600 | 8 | ODD | 2 |
| 16 | 9600 | 8 | EVEN | 1 |
| 17 | 9600 | 8 | EVEN | 2 |
| 18 | 9600 | 7 | NONE | 1 |
| 19 | 9600 | 7 | NONE | 2 |
| 20 | 9600 | 7 | ODD | 1 |
| 21 | 9600 | 7 | ODD | 2 |
| 22 | 9600 | 7 | EVEN | 1 |
| 23 | 9600 | 7 | EVEN | 2 |









| Value | Communication | | | |
|-------|---------------|---|------|---|
| 24 | 19200 | 8 | NONE | 1 |
| 25 | 19200 | 8 | NONE | 2 |
| 26 | 19200 | 8 | ODD | 1 |
| 27 | 19200 | 8 | ODD | 2 |
| 28 | 19200 | 8 | EVEN | 1 |
| 29 | 19200 | 8 | EVEN | 2 |
| 30 | 19200 | 7 | NONE | 1 |
| 31 | 19200 | 7 | NONE | 2 |
| 32 | 19200 | 7 | ODD | 1 |
| 33 | 19200 | 7 | ODD | 2 |
| 34 | 19200 | 7 | EVEN | 1 |
| 35 | 19200 | 7 | EVEN | 2 |

| Value | Communication | | | |
|-------|---------------|---|------|---|
| 36 | 38400 | 8 | NONE | 1 |
| 37 | 38400 | 8 | NONE | 2 |
| 38 | 38400 | 8 | ODD | 1 |
| 39 | 38400 | 8 | ODD | 2 |
| 40 | 38400 | 8 | EVEN | 1 |
| 41 | 38400 | 8 | EVEN | 2 |
| 42 | 38400 | 7 | NONE | 1 |
| 43 | 38400 | 7 | NONE | 2 |
| 44 | 38400 | 7 | ODD | 1 |
| 45 | 38400 | 7 | ODD | 2 |
| 46 | 38400 | 7 | EVEN | 1 |
| 47 | 38400 | 7 | EVEN | 2 |

| @GCF / @SCF | | RS-232C communication mode |
|-----------------|-------------|---|
| Getting | Command | @GCF  |
| | Response | @GCF, mode_1, ..., mode_11  |
| Setting | Command | @SCF, port, mode  |
| | Response | @SCF, port, mode  |
| Parameter | | <p>mode: Operation mode mode_1: Operation mode of RS-232C connector mode_2: Operation mode of HDBaseT input connector IN5 mode_3: Operation mode of HDBaseT input connector IN6 mode_4 to mode_7: Operation mode of HDBaseT output connector OUT1 to OUT4 0 = RECEIVER mode [Default], 1 = TRANSMITTER mode</p> <p>port: RS-232C channel 0 = All channels, 1 = RS-232C connector, 2 = IN5, 3 = IN6, 4 = OUT1, 5 = OUT2, 6 = OUT3, 7 = OUT4</p> |
| Getting example | Command | @GCF  |
| | Response | @GCF,1,1,1,1,1,1,1  |
| | Description | Getting the set operation mode TRANSMITTER mode |
| Setting example | Command | @SCF,1,1  |
| | Response | @SCF,1,1  |
| | Description | Setting RS-232C connector to TRANSMITTER mode. |
| Remarks | | <p>These commands are only for RS-232C.</p> <p>If IP address or RS-232C communication setting is changed, the communication may be disabled. Change the environmental settings based on the MSD settings.</p> |

| @GCI / @SCI | | RS-232C transmission |
|-----------------|-------------|--|
| Getting | Command | @GCI ↵ |
| | Response | @GCI, mode ↵ |
| Setting | Command | @SCI, mode ↵ |
| | Response | @SCI, mode ↵ |
| Parameter | | mode: RS-232C transmission mode 0 = RS-232C transmission mode OFF, 1 = RS-232C transmission mode ON |
| Getting example | Command | @GCI ↵ |
| | Response | @GCI,0 ↵ |
| | Description | Getting the set RS-232C transmission mode. Setting the RS-232C transmission mode to OFF. |
| Setting example | Command | @SCI,1 ↵ |
| | Response | @SCI,1 ↵ |
| | Description | Setting the RS-232C transmission mode to ON. |
| Remarks | | Once RS-232C transmission mode is set to ON, the RS-232C connector cannot be used for communication command control from PC to the MSD or for control command output from the MSD to external devices. Only the command that sets the RS-232C transmission setting to OFF can be accepted. |

| @GCQ / @SCQ | | RS-232C HDBaseT sending channel |
|--------------------|-------------|---|
| Getting | Command | @GCQ  |
| | Response | @GCQ, ch_1 (,ch_2,...,ch_10)  |
| Setting | Command | @SCQ, ch_1 (,ch_2,...)  |
| | Response | @SCQ, ch_1 (,ch_2,...)  |
| Parameter | | ch_1-6: RS-232C HDBaseT sending channel 0 = All OUTB channels, 1 = OUT1B to 4 = OUT4B, 105 = IN5B to 106 = IN6B |
| Getting example | Command | @GCQ  |
| | Response | @GCQ,1,2,3,4  |
| | Description | Getting the set RS-232C HDBaseT sending channel. Setting the OUT1B to OUT4B to RS-232C HDBaseT sending channel. |
| Setting example | Command | @SCQ,1,4  |
| | Response | @SCQ,1,4  |
| | Description | Setting the OUT1B and OUT4B to RS-232C HDBaseT sending channel. |
| Remarks | | — |

| @GCR / @SCR | | RS-232C HDBaseT receiving channel |
|--------------------|-------------|---|
| Getting | Command | @GCR  |
| | Response | @GCR, channel  |
| Setting | Command | @SCR, channel  |
| | Response | @SCR, channel  |
| Parameter | | channel: RS-232C HDBaseT receiving channel 1 = OUT1B to 4 = OUT4B, 105 = IN5B to 106 = IN6B |
| Getting example | Command | @GCR  |
| | Response | @GCR,4  |
| | Description | Getting the set RS-232C HDBaseT receiving channel setting. Setting the OUT4B to RS-232C HDBaseT receiving channel setting. |
| Setting example | Command | @SCR,1  |
| | Response | @SCR,1  |
| | Description | Setting the OUT1B to RS-232C HDBaseT receiving channel setting. |
| Remarks | | Only one channel can be set for receiving channel. |









3.3.13 LAN communication





| @GIP / @SIP | | IP address |
|-----------------|-------------|--|
| Getting | Command | @GIP ↵ |
| | Response | @GIP, unit_1, unit_2, unit_3, unit_4 ↵ |
| Setting | Command | @SIP, unit_1, unit_2, unit_3, unit_4 ↵ |
| | Response | @SIP, unit_1, unit_2, unit_3, unit_4 ↵ |
| Parameter | | unit_1 : Upper bit of the IP address to unit_4 : lower bit of the IP address 0 to 255 = 8 bit (Decimal notation) [Default]192.168.1.199 |
| Getting example | Command | @GIP ↵ |
| | Response | @GIP,192,168,3,2 ↵ |
| | Description | Getting the IP address of the MSD. IP address: 192.168.3.2 |
| Setting example | Command | @SIP,192,168,3,2 ↵ |
| | Response | @SIP,192,168,3,2 ↵ |
| | Description | Setting IP address to 192.168.3.2. |
| Remarks | | If IP address or RS-232C communication setting is changed, the communication may be disabled. Change the environmental settings based on the MSD settings. |

| @GSB / @SSB | | Subnet mask |
|--------------------|-------------|--|
| Getting | Command | @GSB ↵ |
| | Response | @GSB, unit_1, unit_2, unit_3, unit_4 ↵ |
| Setting | Command | @SSB, unit_1, unit_2, unit_3, unit_4 ↵ |
| | Response | @SSB, unit_1, unit_2, unit_3, unit_4 ↵ |
| Parameter | | unit_1 : Upper bit of the subnet mask to unit_4: lower bit of the subnet mask 0 to 255 = 8 bit (Decimal notation) [Default] 255.255.255.0 |
| Getting example | Command | @GSB ↵ |
| | Response | @GSB,255,255,192,0 ↵ |
| | Description | Getting the set subnet mask of the MSD. Subnet mask: 255.255.192.0 (= 18 bit) |
| Setting example | Command | @SSB,255,255,192,0 ↵ |
| | Response | @SSB,255,255,192,0 ↵ |
| | Description | Setting subnet mask to 255.255.192.0 (= 18 bit). |
| Remarks | | If IP address or RS-232C communication setting is changed, the communication may be disabled. Change the environmental settings based on the MSD settings. |

| @GGW / @SGW | | Gateway address |
|--------------------|-------------|--|
| Getting | Command | @GGW ↵ |
| | Response | @GGW, unit_1, unit_2, unit_3, unit_4 ↵ |
| Setting | Command | @SGW, unit_1, unit_2, unit_3, unit_4 ↵ |
| | Response | @SGW, unit_1, unit_2, unit_3, unit_4 ↵ |
| Parameter | | unit_1: Upper bit of the gateway address to unit_4: lower bit of the gateway address 0 to 255 = 8 bit (Decimal notation) [Default]192.168.1.200 |
| Getting example | Command | @GGW ↵ |
| | Response | @GGW,192,168,1,254 ↵ |
| | Description | Getting the set gateway address. Gateway address: 192.168.1.254 |
| Setting example | Command | @SGW,192,168,1,254 ↵ |
| | Response | @SGW,192,168,1,254 ↵ |
| | Description | Setting gateway address to 192.168.1.254. |
| Remarks | | If IP address or RS-232C communication setting is changed, the communication may be disabled. Change the environmental settings based on the MSD settings. |

| @GLF / @SLF | | LAN communication mode |
|-----------------|-------------|---|
| Getting | Command | @GLF, connection <input type="checkbox"/> |
| | Response | @GLF, connection, mode (, ip_1, ip_2, ip_3, ip_4, pjlink, tcp, password) <input type="checkbox"/> |
| Setting | Command | @SLF, connection, mode (, ip_1, ip_2, ip_3, ip_4, pjlink, tcp, password) <input type="checkbox"/> |
| | Response | @SLF, connection, mode (, ip_1, ip_2, ip_3, ip_4, pjlink, tcp, password) <input type="checkbox"/> |
| Parameter | | <p>connection: Connection number 1 = connection 1 to 8 = connection8</p> <p>mode: Operation mode 0 = RECEIVER mode [Default], 1 = TRANSMITTER mode</p> <p>ip_1: Upper bit of the destination IP address to ip_4: lower bit of the destination IP address 0 to 255 = 8 bit (Decimal notation) [Default] 192.168.1.198 Available only if the <i>mode</i> is TRANSMITTER.</p> <p>pjlink: PJLink protocol connection 0 = PJLink not used [Default], 1 = PJLink used Available only if the <i>mode</i> is TRANSMITTER.</p> <p>tcp: Destination port number 1 to 65535 [Default] 1100 Available only if the <i>mode</i> is TRANSMITTER and "pjlink" is set to "0" (PJLink not used). If "pjlink" is set to "1" (PJLink used), "tcp" is "4352" fixed.</p> <p>password: Password of PJLink protocol Up to 32 characters of the following ASCII codes: 20, 30 to 39, 41 to 5A, 61 to 7A (alphanumeric characters). [Default] All: 20 (space) Replied/Set only if the <i>mode</i> is "1" (TRANSMITTER) and <i>pjlink</i> is "0" (PJLink not used). Getting commands: replied only if the password is set. Setting commands: you can skip this password setting if you disable password authentication for PJLink protocol connection. Available only if the <i>mode</i> is TRANSMITTER and "pjlink" is set to "0" (PJLink not used). Getting commands: returned only if the password is set. Setting commands: you can skip this password setting if you do not use password authentication for PJLink protocol connection.</p> |
| Getting example | Command | @GLF,3 <input type="checkbox"/> |
| | Response | @GLF,3,1,192,168,1,2,1,PROJECTOR1 <input type="checkbox"/> |
| Setting example | Description | Getting mode settings of connection 3. Mode = TRANSMITTER mode, destination IP address = 192.168.1.2, PJLink = to be used, password = "PROJECTOR1" |
| | Command | @SLF,3,1,192,168,1,2,1 <input type="checkbox"/> |
| Setting example | Response | @SLF,3,1,192,168,1,2,1 <input type="checkbox"/> |
| | Description | Setting connection 3 as follows: Mode = TRANSMITTER mode, destination IP address = 192.168.1.2, PJLink = to be used, password = disabling password authentication. |
| Remarks | | If IP address or RS-232C communication setting is changed, the communication may be disabled. Change the environmental settings based on the MSD settings. |

| @GLP / @SLP | | TCP port number |
|--------------------|-------------|---|
| Getting | Command | @GLP  |
| | Response | @GLP, port_1, port_2, port_3, port_4, port_5, port_6, port_7, port_8  |
| Setting | Command | @SLP, connection_1, port_1 (, connection_2, port_2···)  |
| | Response | @SLP, connection_1, port_1 (, connection_2, port_2···)  |
| Parameter | | <p>connection_1-8: Connection number 0 = All connections, 1 = Connection 1 to 8 = Connection 8</p> <p>port_1-8: TCP port number 23, 80, 1100, 5000 to 5999, 6000 to 6999 [Default] Connection 1 to 3 = 1100, Connection 4 to 6 = 23, Connection 7 to 8 = 80</p> |
| Getting example | Command | @GLP  |
| | Response | @GLP,1100,1100,1100,23,23,23,80,80  |
| | Description | Getting the set TCP port number. Connection 1 to 3: 1100, Connection 4 to 6: 23, Connection 7 and 8: 80 |
| Setting example | Command | @SLP,8,6000  |
| | Response | @SLP,8,6000  |
| | Description | Setting port number of connection 8 to "6000". |
| Remarks | | If IP address or RS-232C communication setting is changed, the communication may be disabled. Change the environmental settings based on the MSD settings. |



| @GMC | | MAC address |
|-----------------|-------------|--|
| Getting | Command | @GMC  |
| | Response | @GMC, unit_1, unit_2, unit_3, unit_4, unit_5, unit_6  |
| Parameter | | unit_1: Upper bit of the MAC address to unit_6: lower bit of the MAC address 00 to FF = 8 bit (in hexadecimal) |
| Getting example | Command | @GMC  |
| | Response | @GMC,00,08,E5,5F,00,00  |
| | Description | Getting the set MAC address. MAC address: 00-08-E5-5F-00-00 |
| Remarks | | — |

3.3.14 Control commands

| @EXC | | Executing control commands |
|-----------------|-------------|--|
| Setting | Command | @EXC, command_1 (, command_2···) ↵ |
| | Response | @EXC, command_1 (, command_2···) ↵ |
| Parameter | | command_1-5: Control command 1 = COMMAND 1 to 32 = COMMAND 32 |
| Setting example | Command | @EXC,1,2,3 ↵ |
| | Response | @EXC,1,2,3 ↵ |
| | Description | Executing COMMAND 1→2→3 in order. |
| Setting example | Command | @EXC,6 ↵ |
| | Response | @EXC,6,RECV:POWER OFF ↵ |
| | Description | Executing COMMAND 6. If a command to display received data is executed, the received result is returned. In this example, "POWER OFF" is received from the target device. |
| Remarks | | Since the result is returned after control command execution is complete, it sometimes may take a time for response. |

| @GDS / @SDS | | Power button of sink device |
|--------------------|-------------|--|
| Getting | Command | @GDS ↵ |
| | Response | @GDS, onoff_1, onoff_2, onoff_3, onoff_4 ↵ |
| Setting | Command | @SDS, ch_1, onoff_1 (, ch_2, onoff_2···) ↵ |
| | Response | @SDS, ch_1, onoff_1 (, ch_2, onoff_2···) ↵ |
| Parameter | | onoff_1-4: Power button of sink device 0 = OFF, 1 = ON ch_1-4: Output channel 0 = All outputs, 1 = OUT1 to 4 = OUT4 |
| Getting example | Command | @GDS ↵ |
| | Response | @GDS,1,1,1,1,1,1,1,1 ↵ |
| | Description | Getting the power button status of sink device. OUT1 and OUT4 powered ON |
| Setting example | Command | @SDS,1,1 ↵ |
| | Response | @SDS,1,1 ↵ |
| | Description | Setting the power button of the sink device that is connected OUT1 to ON. |
| Remarks | | Since the result is returned after control command execution is complete, it sometimes may take a time for response. |

| @GEC / @SEC | | Control command (Communication command) | | | | | | | | | | | | | | | | | | | | | | | | | | | | | | | | | | | | | | | | | | | | | | | | | | | | | | |
|-------------|----------|---|-------|-------|-------|-----------|-------|---------|---|---|---|------|-------|-------|-------|-------|-------|-------|---|---------|-----|----|----|----|----|----|----|---|---|------|---|------|------|---|---|-----------|-------|-------|-----|----|----|----|----|----|----|----|----|------|---|---|---|---|-------|-------|-------|-------|
| Getting | Command | @GEC, no [↵] | | | | | | | | | | | | | | | | | | | | | | | | | | | | | | | | | | | | | | | | | | | | | | | | | | | | | | |
| | Response | @GEC, no, delay, port, memo, length, command, timeout, retry, interval, retryover, display (, recv_1, recv_2···) [↵] | | | | | | | | | | | | | | | | | | | | | | | | | | | | | | | | | | | | | | | | | | | | | | | | | | | | | | |
| Setting | Command | @SEC, no, delay, port, memo, length, command, timeout, retry, interval, retryover, display (, recv_1, recv_2···) [↵] | | | | | | | | | | | | | | | | | | | | | | | | | | | | | | | | | | | | | | | | | | | | | | | | | | | | | | |
| | Response | @SEC, no, delay, port, memo, length, command, timeout, retry, interval, retryover, display (, recv_1, recv_2···) [↵] | | | | | | | | | | | | | | | | | | | | | | | | | | | | | | | | | | | | | | | | | | | | | | | | | | | | | | |
| Parameter | | <p>no: Control command number 1 to 32</p> <p>delay: Delay time 0 = 0 sec. to 999999 = 999.999 sec.</p> <p>port: Output port 1 to 1009661</p> <table border="1"> <tr> <td>bit</td> <td>7</td> <td>6</td> <td>5</td> <td>4</td> <td>3</td> <td>2</td> <td>1</td> <td>0</td> </tr> <tr> <td>port</td> <td>LAN 6</td> <td>LAN 5</td> <td>LAN 4</td> <td>LAN 3</td> <td>LAN 2</td> <td>LAN 1</td> <td>—</td> <td>RS-232C</td> </tr> </table> <table border="1"> <tr> <td>bit</td> <td>15</td> <td>14</td> <td>13</td> <td>12</td> <td>11</td> <td>10</td> <td>9</td> <td>8</td> </tr> <tr> <td>port</td> <td>—</td> <td>IN6B</td> <td>IN5B</td> <td>—</td> <td>—</td> <td>LOOP BACK</td> <td>LAN 8</td> <td>LAN 7</td> </tr> </table> <table border="1"> <tr> <td>bit</td> <td>23</td> <td>22</td> <td>21</td> <td>20</td> <td>19</td> <td>18</td> <td>17</td> <td>16</td> </tr> <tr> <td>port</td> <td>—</td> <td>—</td> <td>—</td> <td>—</td> <td>OUT4B</td> <td>OUT3B</td> <td>OUT2B</td> <td>OUT1B</td> </tr> </table> <p>“1” is for the bit of the output port to send a command (Since bit 1, 11, 12, 15, 20 to 23 are not used, they are always “0”). For example, if you want to send a command from RS-232C CH1, specify “1”. If sending a command from LAN 2, specify “8”.</p> <p>memo: Up to 14 characters of 20 to 7D except 2C (,).</p> <p>length: Data size of send command (the number of bytes) 0 to 30</p> <p>command: Send command data Specify <i>length</i> × 2 digits with 0 to 9, A to F, a to f: (4 bit per digit in hexadecimal).</p> <p>timeout: Time-out duration 0 = 0 sec. to 99999 = 99.999 sec.</p> <p>retry: The number of retries 0 to 99</p> <p>interval: Retry interval 0 = 0 sec. to 99999 = 99.999 sec.</p> <p>retryover: Processing at retry over 0 = Stop processing, 1 = Continue processing</p> <p>display: Displaying received data 0 = communication command control</p> | bit | 7 | 6 | 5 | 4 | 3 | 2 | 1 | 0 | port | LAN 6 | LAN 5 | LAN 4 | LAN 3 | LAN 2 | LAN 1 | — | RS-232C | bit | 15 | 14 | 13 | 12 | 11 | 10 | 9 | 8 | port | — | IN6B | IN5B | — | — | LOOP BACK | LAN 8 | LAN 7 | bit | 23 | 22 | 21 | 20 | 19 | 18 | 17 | 16 | port | — | — | — | — | OUT4B | OUT3B | OUT2B | OUT1B |
| bit | 7 | 6 | 5 | 4 | 3 | 2 | 1 | 0 | | | | | | | | | | | | | | | | | | | | | | | | | | | | | | | | | | | | | | | | | | | | | | | | |
| port | LAN 6 | LAN 5 | LAN 4 | LAN 3 | LAN 2 | LAN 1 | — | RS-232C | | | | | | | | | | | | | | | | | | | | | | | | | | | | | | | | | | | | | | | | | | | | | | | | |
| bit | 15 | 14 | 13 | 12 | 11 | 10 | 9 | 8 | | | | | | | | | | | | | | | | | | | | | | | | | | | | | | | | | | | | | | | | | | | | | | | | |
| port | — | IN6B | IN5B | — | — | LOOP BACK | LAN 8 | LAN 7 | | | | | | | | | | | | | | | | | | | | | | | | | | | | | | | | | | | | | | | | | | | | | | | | |
| bit | 23 | 22 | 21 | 20 | 19 | 18 | 17 | 16 | | | | | | | | | | | | | | | | | | | | | | | | | | | | | | | | | | | | | | | | | | | | | | | | |
| port | — | — | — | — | OUT4B | OUT3B | OUT2B | OUT1B | | | | | | | | | | | | | | | | | | | | | | | | | | | | | | | | | | | | | | | | | | | | | | | | |

| @GEC / @SEC | | Control command (Communication command) (cont'd) |
|--------------------|------------------|--|
| Parameter | | rcv_1-32: Presence or absence of response command check 1 to 32 For get commands, reply command numbers are separated from each other by a comma. For set commands, the reply command number to be checked can be specified. Up to 32 commands can be specified by separating them by a comma. If you send only parameters of reply command number you want to check, the reply commands without sent parameter are automatically set to "not check". Register reply commands in " @GRC / @SRC Response command ". |
| Getting example | Command Response | @GEC,1  @GEC,1,10,1,POWER,7,5057204F4E0D0A,1000,2,500,0,0,1,2  |
| | Description | Getting settings registered in control command 1. <ul style="list-style-type: none"> ▪ Delay: 10 ms ▪ Output port: RS-232C connector ▪ Memo: POWER ▪ Data size: 7 bytes ▪ Command data: PW ON CR LF (ASCII codes) ▪ Timeout: 1000 ms ▪ Retry: 2 times ▪ Retry interval: 500 ms ▪ Retry over: Stop ▪ Received data: Not displayed ▪ Response command: Check 1 and 2 |
| Setting example | Command Response | @SEC,2,0,1024,IN1 SELECT,10,405353572C312C310D0A,0,0,0,1,0  @SEC,2,0,1024,IN1 SELECT,10,405353572C312C310D0A,0,0,0,1,0  |
| | Description | Setting control command 2 as follows: <ul style="list-style-type: none"> ▪ Delay: 0 ms ▪ Output port: LOOP BACK ▪ Memo: IN1 SELECT ▪ Data size: 10 bytes ▪ Command data: @SSW,1,1 CR LF (ASCII codes) ▪ Timeout: 0 ms ▪ Retry: 0 time ▪ Interval: 0 ms ▪ Retry over: Execute ▪ Received data: Not displayed ▪ Response command: Not checked |
| Remarks | | — |









| @GEC / @SEC | | Control command (Displaying received data) | | | | | | | | | | | | | | | | | | |
|--|----------|--|-------|-------|-------|-------|-------|-----------|-------|---------|----|------|-------|-------|-------|-------|-------|-----------|-------|---------|
| Getting | Command | @GEC, no ↵ | | | | | | | | | | | | | | | | | | |
| | Response | @GEC, no, delay, port, memo, length, command, timeout, retry, interval, retryover, display, delimiter ↵ | | | | | | | | | | | | | | | | | | |
| Setting | Command | @SEC, no, delay, port, memo, length, command, timeout, retry, interval, retryover, display, delimiter ↵ | | | | | | | | | | | | | | | | | | |
| | Response | @SEC, no, delay, port, memo, length, command, timeout, retry, interval, retryover, display, delimiter ↵ | | | | | | | | | | | | | | | | | | |
| Parameter | | no: Control command number 1 to 32 | | | | | | | | | | | | | | | | | | |
| | | delay: Delay time 0 = 0 sec. to 999999 = 999.999 sec. | | | | | | | | | | | | | | | | | | |
| | | port: Output port 1 to 1009661 | | | | | | | | | | | | | | | | | | |
| | | <table border="1"> <tr> <td>bit</td> <td>7</td> <td>6</td> <td>5</td> <td>4</td> <td>3</td> <td>2</td> <td>1</td> <td>0</td> </tr> <tr> <td>port</td> <td>LAN 6</td> <td>LAN 5</td> <td>LAN 4</td> <td>LAN 3</td> <td>LAN 2</td> <td>LAN 1</td> <td>—</td> <td>RS-232C</td> </tr> </table> | bit | 7 | 6 | 5 | 4 | 3 | 2 | 1 | 0 | port | LAN 6 | LAN 5 | LAN 4 | LAN 3 | LAN 2 | LAN 1 | — | RS-232C |
| | | bit | 7 | 6 | 5 | 4 | 3 | 2 | 1 | 0 | | | | | | | | | | |
| | | port | LAN 6 | LAN 5 | LAN 4 | LAN 3 | LAN 2 | LAN 1 | — | RS-232C | | | | | | | | | | |
| | | <table border="1"> <tr> <td>bit</td> <td>15</td> <td>14</td> <td>13</td> <td>12</td> <td>11</td> <td>10</td> <td>9</td> <td>8</td> </tr> <tr> <td>port</td> <td>—</td> <td>IN6B</td> <td>IN5B</td> <td>—</td> <td>—</td> <td>LOOP BACK</td> <td>LAN 8</td> <td>LAN 7</td> </tr> </table> | bit | 15 | 14 | 13 | 12 | 11 | 10 | 9 | 8 | port | — | IN6B | IN5B | — | — | LOOP BACK | LAN 8 | LAN 7 |
| | | bit | 15 | 14 | 13 | 12 | 11 | 10 | 9 | 8 | | | | | | | | | | |
| | | port | — | IN6B | IN5B | — | — | LOOP BACK | LAN 8 | LAN 7 | | | | | | | | | | |
| | | <table border="1"> <tr> <td>bit</td> <td>23</td> <td>22</td> <td>21</td> <td>20</td> <td>19</td> <td>18</td> <td>17</td> <td>16</td> </tr> <tr> <td>port</td> <td>—</td> <td>—</td> <td>—</td> <td>—</td> <td>OUT4B</td> <td>OUT3B</td> <td>OUT2B</td> <td>OUT1B</td> </tr> </table> | bit | 23 | 22 | 21 | 20 | 19 | 18 | 17 | 16 | port | — | — | — | — | OUT4B | OUT3B | OUT2B | OUT1B |
| | | bit | 23 | 22 | 21 | 20 | 19 | 18 | 17 | 16 | | | | | | | | | | |
| | | port | — | — | — | — | OUT4B | OUT3B | OUT2B | OUT1B | | | | | | | | | | |
| | | <p>“1” is for the output port to send a command (Since bit 1, 11, 12, 15, 20 to 23 are not used, they are always “0”). For example, if you want to send a command to RS-232C, specify “1”. If sending a command to LAN 2, specify “8”.</p> | | | | | | | | | | | | | | | | | | |
| | | memo: Up to 14 characters of 20 to 7D except 2C (,) from ASCII codes. | | | | | | | | | | | | | | | | | | |
| length: Command data size (the number of bites) 0 to 30 | | | | | | | | | | | | | | | | | | | | |
| command: Command data Specify length × 2 digits with 0 to 9, A to F, a to f = 4 bit per digit (in hexadecimal). | | | | | | | | | | | | | | | | | | | | |
| timeout: Time-out duration 0 = 0 sec. to 99999 = 99.999 sec. | | | | | | | | | | | | | | | | | | | | |
| retry: The number of retries 0 to 99 | | | | | | | | | | | | | | | | | | | | |
| interval: Retry interval 0 = 0 sec. to 99999 = 99.999 sec. | | | | | | | | | | | | | | | | | | | | |
| retryover: Processing at retry over 0 = Stop processing, 1 = Continue processing | | | | | | | | | | | | | | | | | | | | |
| display: Displaying received data 1 = in ASCII codes, 2 = in hexadecimals | | | | | | | | | | | | | | | | | | | | |
| delimiter 2 digits of 0 to 9, A to F, a to f = 4 bit per digit (in hexadecimal) for monitoring delimiter 100 = Not monitor | | | | | | | | | | | | | | | | | | | | |

| @GEC / @SEC | | Control command (Displaying received data) (cont'd) |
|-----------------|-------------|---|
| Getting example | Command | @GEC,3 ↵ |
| | Response | @GEC,3,0,8,POWER STATUS,9,47455420504F570D0A,2000,2,200,0,1,0D ↵ |
| | Description | Getting settings of control command 3. <ul style="list-style-type: none"> ▪ Delay time: 0 ms ▪ Output port: LAN2 ▪ Memo: POWER STATUS ▪ Data size: 9 bytes ▪ Command data: GET POW CR LF (ASCII codes) ▪ Timeout: 2000 ms ▪ Retry: 2 times ▪ Retry interval: 200 ms ▪ Retryover: Stop ▪ Received data: Displayed in ASCII codes ▪ Delimiter: 0D in hex (CR =ASCII codes) |
| Setting example | Command | @SEC,3,0,8,POWER STATUS,9,47455420504F570D0A,2000,2,200,0,1,0D ↵ |
| | Response | @SEC,3,0,8,POWER STATUS,9,47455420504F570D0A,2000,2,200,0,1,0D ↵ |
| | Description | Setting control command 3 as follows: <ul style="list-style-type: none"> ▪ Delay time: 0 ms ▪ Output port: LAN2 ▪ Memo: POWER STATUS ▪ Data size: 9 bytes ▪ Command data: GET POW CR LF (ASCII codes) ▪ Timeout: 2000 ms ▪ Retry: 2 times ▪ Retry interval: 200 ms ▪ Retryover: Stop ▪ Received data: Displayed in ASCII codes ▪ Delimiter: 0D in hex (CR =ASCII codes) |
| Remarks | | — |

| @GEC / @SEC | | Control command (contact closure) | | | | | | | | | | | | | | | | | | | | | | | | | | | | | | |
|-----------------|-------------------|--|------|-------------------|-----|-----|-------------------|-----|-----|---|---|---|-----------------|-------------------|--|--|-------------------|--|--|-------------------|--|--|--|-----|-----|-----|-----|-----|-----|-----|-----|-----|
| Getting | Command | @GEC, no [↵] | | | | | | | | | | | | | | | | | | | | | | | | | | | | | | |
| | Response | @GEC, no, delay, port, memo, ccno_1, cc_1, pulse_1 (, ccno_2, cc_2, pulse_2···) [↵] | | | | | | | | | | | | | | | | | | | | | | | | | | | | | | |
| Setting | Command | @SEC, no, delay, port, memo, ccno_1, cc_1, pulse_1 (, ccno_2, cc_2, pulse_2···) [↵] | | | | | | | | | | | | | | | | | | | | | | | | | | | | | | |
| | Response | @SEC, no, delay, port, memo, ccno_1, cc_1, pulse_1 (, ccno_2, cc_2, pulse_2···) [↵] | | | | | | | | | | | | | | | | | | | | | | | | | | | | | | |
| Parameter | | <p>no: Control command number 1 to 32</p> <p>delay: Delay time 0 = 0 sec. to 999999 = 999.999 sec.</p> <p>port: Contact closure control 2048= For contact closure control</p> <p>memo: Up to 14 characters of 20 to 7D except 2C (,) from ASCII codes.</p> <p>ccno_1-8: Contact closure number</p> <table border="1" style="width: 100%; border-collapse: collapse; text-align: center;"> <tr> <td style="width: 10%;">ccno</td> <td>1</td> <td>2</td> <td>3</td> <td>4</td> <td>5</td> <td>6</td> <td>7</td> <td>8</td> <td>9</td> </tr> <tr> <td>Contact closure</td> <td colspan="3">CONTACT CLOSURE 1</td> <td colspan="3">CONTACT CLOSURE 2</td> <td colspan="3">CONTACT CLOSURE 3</td> </tr> <tr> <td></td> <td>CH1</td> <td>CH2</td> <td>CH3</td> <td>CH1</td> <td>CH2</td> <td>CH3</td> <td>CH1</td> <td>CH2</td> <td>CH3</td> </tr> </table> <p>cc_1-8: Contact closure control 0 = OFF, 1 = ON, 2 = Toggle, 3 = Not control</p> <p>pulse_1-8: pulse width 0 = Hold, 100 = 100 ms to 9990 = 9990 ms (by 10 ms) Pulse width after the completion of contact closure.</p> <p>Getting commands: only contact closure numbers to be controlled are replied. Setting commands: specify only contact closure numbers to be controlled. For contact closure numbers that do not specify parameter, "Not check" is set.</p> | ccno | 1 | 2 | 3 | 4 | 5 | 6 | 7 | 8 | 9 | Contact closure | CONTACT CLOSURE 1 | | | CONTACT CLOSURE 2 | | | CONTACT CLOSURE 3 | | | | CH1 | CH2 | CH3 | CH1 | CH2 | CH3 | CH1 | CH2 | CH3 |
| ccno | 1 | 2 | 3 | 4 | 5 | 6 | 7 | 8 | 9 | | | | | | | | | | | | | | | | | | | | | | | |
| Contact closure | CONTACT CLOSURE 1 | | | CONTACT CLOSURE 2 | | | CONTACT CLOSURE 3 | | | | | | | | | | | | | | | | | | | | | | | | | |
| | CH1 | CH2 | CH3 | CH1 | CH2 | CH3 | CH1 | CH2 | CH3 | | | | | | | | | | | | | | | | | | | | | | | |
| Getting example | Command | @GEC,7 [↵] | | | | | | | | | | | | | | | | | | | | | | | | | | | | | | |
| | Response | @GEC,7,20,2048,SCREEN UP,1,1,100 [↵] | | | | | | | | | | | | | | | | | | | | | | | | | | | | | | |
| | Description | <p>Getting settings of control command 7.</p> <ul style="list-style-type: none"> ▪ Delay time: 20ms ▪ Memo: SCREEN UP ▪ Contact closure1's CH1: ON for 100 ms ▪ Other outputs: not controlled. | | | | | | | | | | | | | | | | | | | | | | | | | | | | | | |
| Setting example | Command | @SEC,6,50,2048,PROJECTOR ON,1,0,200,2,1,0 [↵] | | | | | | | | | | | | | | | | | | | | | | | | | | | | | | |
| | Response | @SEC,6,50,2048,PROJECTOR ON,1,0,200,2,1,0 [↵] | | | | | | | | | | | | | | | | | | | | | | | | | | | | | | |
| | Description | <p>Setting Control command number 6 as follows:</p> <ul style="list-style-type: none"> ▪ Delay time: 50 ms ▪ Memo: PROJECTOR ON ▪ CH1 of contact closure1 : ON for 200 ms ▪ CH2 of contact closure : ON ▪ Other contact closure : Not controlled | | | | | | | | | | | | | | | | | | | | | | | | | | | | | | |
| Remarks | | — | | | | | | | | | | | | | | | | | | | | | | | | | | | | | | |

| @GEC / @SEC | | Control command (CEC) |
|-----------------|-------------|--|
| Getting | Command | @GEC, no |
| | Response | @GEC, no, delay, port, memo, error, ch_1, cec_1 (, ch_2, cec_2····) |
| Setting | Command | @SEC, no, delay, port, memo, error, ch_1, cec_1 (, ch_2, cec_2····) |
| | Response | @SEC, no, delay, port, memo, error, ch_1, cec_1 (, ch_2, cec_2····) |
| Parameter | | <p>no: Control command number 1 to 32</p> <p>delay: Delay time 0 = 0 sec. to 999999 = 999.999 sec.</p> <p>port: CEC 4096 = For CEC control</p> <p>memo: Up to 14 characters of 20 to 7D except 2C (,) from ASCII codes.</p> <p>error: Processing if no response from sink device. 0 = Stop processing, 1 = Continue processing</p> <p>ch_1-4: Output channel 1 = OUT1 to 4 = OUT4</p> <p>cec_1-8: Control command 0 = Not controlled, 1 = POWER OFF, 2 = POWER ON</p> <p>Getting commands: the control output connector and control command are separated from each other by a comma. Setting commands: specify output connector to be controlled and control commands. For outputs that do not specify parameter, "Not check" is set.</p> |
| Getting example | Command | @GEC,7 |
| | Response | @GEC,7,0,4096,DISPLAY1 ON,0,1,2 |
| | Description | <p>Getting settings of control command 7.</p> <ul style="list-style-type: none"> • Delay time: 0 ms • Memo: DISPLAY1 ON • Error: Stop • OUT1 sink device: Turning on. • Other outputs: not controlled. |
| Setting example | Command | @SEC,7,0,4096,DISPLAY1 ON,0,1,2 |
| | Response | @SEC,7,0,4096,DISPLAY1 ON,0,1,2 |
| | Description | <p>Setting control command 7 as follows:</p> <ul style="list-style-type: none"> • Delay time:0 ms • Memo: DISPLAY1 ON • Error: Stop • OUT1 sink device: Power ON. • Other outputs: not controlled. |
| Remarks | | — |

| @GRC / @SRC | | Response command |
|-----------------|-------------|--|
| Getting | Command | @GRC, no ↵ |
| | Response | @GRC, no, process, length, command, mask, memo ↵ |
| Setting | Command | @SRC, no, process, length, command, mask, memo ↵ |
| | Response | @SRC, no, process, length, command, mask, memo ↵ |
| Parameter | | no: Response command number 1 to 32 |
| | | process 0 = Stop, 1 = Continue, 2 = Resending commands |
| | | length: Reply command data size (bytes) 0 to 30 |
| | | command: Reply command data length × 2 digits with 0 to 9, A to F, a to f = 4 bit per digit (in hexadecimal) |
| | | mask: Mask data length × 2 digits with 0 to 9, A to F, a to f = 4 bit per digit (in hexadecimal) |
| | | memo: Up to 14 characters of 20 to 7D except 2C (,) from ASCII codes. |
| Getting example | Command | @GRC,2 ↵ |
| | Response | @GRC,2,0,1,40,40,NG ↵ |
| | Description | Getting settings of reply command 2: <ul style="list-style-type: none"> ▪ Processing: Stop ▪ Data size: 1 byte ▪ Command data: 40 (in hex) ▪ Mask data: 40 (checking the second bit from the top) ▪ Memo: NG (no good) |
| Setting example | Command | @SRC,1,1,9,52454356204F4B0D0A,FFFFFFFFFFFFFFFFFFFF,OK ↵ |
| | Response | @SRC,1,1,9,52454356204F4B0D0A,FFFFFFFFFFFFFFFFFFFF,OK ↵ |
| | Description | Setting reply command 1 as follows: <ul style="list-style-type: none"> ▪ Processing: Continue ▪ Data size: 9 bytes ▪ Command data: RECV OK CR LF (ASCII) ▪ Mask data: ALL: FF (checking all bits) ▪ Memo: OK |
| Remarks | | — |









| @GCC / @SCC | | Control command link |
|--------------------|-------------|---|
| Getting | Command | @GCC, event  |
| | Response | @GCC, event, c_1 (, c_2, c_3···)  |
| Setting | Command | @SCC, event, c_1 (, c_2, c_3···)  |
| | Response | @SCC, event, c_1 (, c_2, c_3···)  |
| Parameter | | <p>event: Control command execution condition For settable values, see the [Table 3.2].</p> <p>c_1-10: Send command 0 = Not link [Default], 1 to 32 = Control command 1 to 32 Control commands that are registered in one of the following commands can be linked.</p> <p>@GEC / @SEC Control command (Communication command), @GEC / @SEC Control command (Displaying received data), @GEC / @SEC Control command (contact closure), @GEC / @SEC Control command (CEC).</p> |
| Getting example | Command | @GCC,19  |
| | Response | @GCC,19,5,2,1  |
| | Description | Getting control commands that will be executed when the MSD is powered on. Executing in order of control command 5, 2, and 1. |
| Setting example | Command | @SCC,19,5,2,1  |
| | Response | @SCC,19,5,2,1  |
| | Description | Executing in order of control command 5, 2, and 1 when the MSD is powered on. |
| Remarks | | — |





[Table 3.2] Parameter of control command execution condition

| event | Execution condition | event | Execution condition | event | Execution condition |
|-------|---------------------|-------|---------------------|-------|---------------------|
| 1 | COMMAND A-PLANE A | 37 | VIDEO:OUT1-IN1 | 73 | VIDEO:OUT3-IN1 |
| 2 | COMMAND A-PLANE B | 38 | VIDEO:OUT1-IN2 | 74 | VIDEO:OUT3-IN2 |
| 3 | COMMAND B-PLANE A | 39 | VIDEO:OUT1-IN3 | 75 | VIDEO:OUT3-IN3 |
| 4 | COMMAND B-PLANE B | 40 | VIDEO:OUT1-IN4 | 76 | VIDEO:OUT3-IN4 |
| 5 | COMMAND C-PLANE A | 41 | VIDEO:OUT1-IN5 | 77 | VIDEO:OUT3-IN5 |
| 6 | COMMAND C-PLANE B | 42 | VIDEO:OUT1-IN6 | 78 | VIDEO:OUT3-IN6 |
| 7 | COMMAND D-PLANE A | 43 | VIDEO:OUT1-IN7 | 79 | VIDEO:OUT3-IN7 |
| 8 | COMMAND D-PLANE B | 44 | VIDEO:OUT1-IN8 | 80 | VIDEO:OUT3-IN8 |
| 9 | COMMAND E-PLANE A | 45 | VIDEO:OUT1-OFF | 81 | VIDEO:OUT3-OFF |
| 10 | COMMAND E-PLANE B | 46 | AUDIO:OUT1-IN1 | 82 | AUDIO:OUT3-IN1 |
| 11 | COMMAND F-PLANE A | 47 | AUDIO:OUT1-IN2 | 83 | AUDIO:OUT3-IN2 |
| 12 | COMMAND F-PLANE B | 48 | AUDIO:OUT1-IN3 | 84 | AUDIO:OUT3-IN3 |
| 13 | COMMAND G-PLANE A | 49 | AUDIO:OUT1-IN4 | 85 | AUDIO:OUT3-IN4 |
| 14 | COMMAND G-PLANE B | 50 | AUDIO:OUT1-IN5 | 86 | AUDIO:OUT3-IN5 |
| 15 | COMMAND H-PLANE A | 51 | AUDIO:OUT1-IN6 | 87 | AUDIO:OUT3-IN6 |
| 16 | COMMAND H-PLANE B | 52 | AUDIO:OUT1-IN7 | 88 | AUDIO:OUT3-IN7 |
| 17 | COMMAND I-PLANE A | 53 | AUDIO:OUT1-IN8 | 89 | AUDIO:OUT3-IN8 |
| 18 | COMMAND I-PLANE B | 54 | AUDIO:OUT1-OFF | 90 | AUDIO:OUT3-OFF |
| 19 | POWER ON | 55 | VIDEO:OUT2-IN1 | 91 | VIDEO:OUT4-IN1 |
| 20 | POWER OFF | 56 | VIDEO:OUT2-IN2 | 92 | VIDEO:OUT4-IN2 |
| 21 | DISPLAY1 POWER ON | 57 | VIDEO:OUT2-IN3 | 93 | VIDEO:OUT4-IN3 |
| 22 | DISPLAY1 POWER OFF | 58 | VIDEO:OUT2-IN4 | 94 | VIDEO:OUT4-IN4 |
| 23 | DISPLAY2 POWER ON | 59 | VIDEO:OUT2-IN5 | 95 | VIDEO:OUT4-IN5 |
| 24 | DISPLAY2 POWER OFF | 60 | VIDEO:OUT2-IN6 | 96 | VIDEO:OUT4-IN6 |
| 25 | DISPLAY3 POWER ON | 61 | VIDEO:OUT2-IN7 | 97 | VIDEO:OUT4-IN7 |
| 26 | DISPLAY3 POWER OFF | 62 | VIDEO:OUT2-IN8 | 98 | VIDEO:OUT4-IN8 |
| 27 | DISPLAY4 POWER ON | 63 | VIDEO:OUT2-OFF | 99 | VIDEO:OUT4-OFF |
| 28 | DISPLAY4 POWER OFF | 64 | AUDIO:OUT2-IN1 | 100 | AUDIO:OUT4-IN1 |
| | | 65 | AUDIO:OUT2-IN2 | 101 | AUDIO:OUT4-IN2 |
| | | 66 | AUDIO:OUT2-IN3 | 102 | AUDIO:OUT4-IN3 |
| | | 67 | AUDIO:OUT2-IN4 | 103 | AUDIO:OUT4-IN4 |
| | | 68 | AUDIO:OUT2-IN5 | 104 | AUDIO:OUT4-IN5 |
| | | 69 | AUDIO:OUT2-IN6 | 105 | AUDIO:OUT4-IN6 |
| | | 70 | AUDIO:OUT2-IN7 | 106 | AUDIO:OUT4-IN7 |
| | | 71 | AUDIO:OUT2-IN8 | 107 | AUDIO:OUT4-IN8 |
| | | 72 | AUDIO:OUT2-OFF | 108 | AUDIO:OUT4-OFF |

| @GTG / @STG | | Toggle operation |
|--------------------|-------------|--|
| Getting | Command | @GTG, event_1 (, event_2····) |
| | Response | @GTG, event_1, toggle_1 (, event_2, toggle_2····) |
| Setting | Command | @STG, event_1, toggle_1 (, event_2, toggle_2····) |
| | Response | @STG, event_1, toggle_1 (, event_2, toggle_2····) |
| Parameter | | event_1-9: Command execution condition 0 = All control commands, 1 = COMMAND A to 9 = COMMAND I |
| | | toggle_1-9: Toggle operation 0 = Disabled [Default], 1 = Enabled |
| Getting example | Command | @GTG,1 |
| | Response | @GTG,1,1 |
| | Description | Getting the toggle operation of COMMAND A. COMMAND A: Toggle operation enabled. |
| Setting example | Command | @STG,1,1 |
| | Response | @STG,1,1 |
| | Description | Enabling COMMAND A's toggle operation COMMAND A. |
| Remarks | | — |

| @GUP / @SUP | | Plane to be executed when powered ON |
|--------------------|-------------|--|
| Getting | Command | @GUP, event_1 (, event_2····) |
| | Response | @GUP, event_1, plane_1 (, event_2, plane_2····) |
| Setting | Command | @SUP, event_1, plane_1 (, event_2, plane_2····) |
| | Response | @SUP, event_1, plane_1 (, event_2, plane_2····) |
| Parameter | | event_1-9: Command execution condition 0 = All control commands, 1 = COMMAND A to 9 = COMMAND I |
| | | plane_1-9: Plane to be executed when powered ON 0 = AUTO [Default], 1 = PLANE A, 2 = PLANE B |
| Getting example | Command | @GUP,1 |
| | Response | @GUP,1,1 |
| | Description | Getting the plane to be executed for COMMAND A. COMMAND A executes PLANE A. |
| Setting example | Command | @SUP,1,1 |
| | Response | @SUP,1,1 |
| | Description | Setting COMMAND A to execute PLANE A. |
| Remarks | | — |

| @GIT / @SIT | | Ineffective time during control command execution |
|--------------------|-------------|--|
| Getting | Command | @GIT  |
| | Response | @GIT, time  |
| Setting | Command | @SIT, time  |
| | Response | @SIT, time  |
| Parameter | | time: Invalid time 0 = 0 sec. to 999999 = 999.999 sec. [Default] 0 sec. |
| Getting example | Command | @GIT  |
| | Response | @GIT,2000  |
| | Description | Getting ineffective time of control command execution. Disabling operation during control command execution or 2000 ms. (2 seconds) after control command starts. |
| Setting example | Command | @SIT,2000  |
| | Response | @SIT,2000  |
| | Description | Setting ineffective time during control command execution to 2000 ms. (2 seconds). |
| Remarks | | — |

| @DEC | | Initializing registered command and link |
|-----------------|-------------|---|
| Setting | Command | @DEC, no_1 (, no_2, no_3···)  |
| | Response | @DEC, no_1 (, no_2, no_3···)  |
| Parameter | | no_1-32: Commands or links you want to initialize 1 to 32: Control commands 1 to 32 101 to 132: Response commands 1 to 32 ("1xx": xx is the response command number) 【See: @GRC / @SRC Response command】 201 to 380: Control command links 1 to 5 ("2xx": xx is the control command execution condition) 【See: @GCC / @SCC Control command link】 |
| Setting example | Command | @DEC,201  |
| | Response | @DEC,201  |
| | Description | Deleting the link between COMMAND A and PLANE A. |
| Remarks | | — |

| @GTL / @STL | | Lighting condition of execution button |
|-----------------|-------------|---|
| Getting | Command | @GTL, switch_1 (, switch_2····) ↵ |
| | Response | @GTL, switch_1, led_1 (, switch_2, led_2····) ↵ |
| Setting | Command | @STL, switch_1, led_1 (, switch_2, led_2····) ↵ |
| | Response | @STL, switch_1, led_1 (, switch_2, led_2····) ↵ |
| Parameter | | <p>switch_1-9: Command execution button 0 = All command execution buttons 1 = COMMAND A to 9 = COMMAND I</p> <p>led_1-9 : Lighting condition If a control command(s) having only one PLANE, PLANE A or PLANE B is linked to a control command execution button: 0 = Lights when a control command is registered. [Default] 1 = Lights while a control command is being executed.</p> <p>If a control command(s) having two PLANEs, PLANE A and PLANE B is linked to a control command execution button: 0 = A control command(s) that is linked to a button is executed by pressing the desired button when the control command execution button lights/blinks. Lights: Control command registered to PLANE A. Blinks: Control command registered to PLANE B. 1 = The control command that is linked to a button is executed by pressing a desired button when the control command execution button lights/goes out. Lights: Control command registered to PLANE A Goes out: Control command registered to PLANE B</p> |
| Getting example | Command | @GTL,5 ↵ |
| | Response | @GTL,5,0 ↵ |
| | Description | Getting the lighting condition of the COMMAND E. The COMMAND E lights if a control command is registered. (If one PLANE is linked) |
| Setting example | Command | @STL,5,1 ↵ |
| | Response | @STL,5,1 ↵ |
| | Description | Setting the COMMAND E to light while a command is being executed. (If one PLANE is linked) |
| Remarks | | — |

| @GTF / @STF | | Blinking time of sink device power switch |
|--------------------|-------------|---|
| Getting | Command | @GTF, switch_1 (, switch_2···) ↵ |
| | Response | @GTF, switch_1, flash_1 (, switch_2, flash_2···) ↵ |
| Setting | Command | @STF, switch_1, flash_1 (, switch_2, flash_2···) ↵ |
| | Response | @STF, switch_1, flash_1 (, switch_2, flash_2···) ↵ |
| Parameter | | switch_1-9: Key group 0 = All keys, 1 = COMMAND A to 5 = COMMAND E 10 = DISPLAY1 POWER to 13 = DISPLAY4 POWER flash_1-9: Blinking time -1 = Links during control command execution, 0 = Not blink, 1 to 1000 = Blinks for 1 sec. to 1000 sec. [Default] COMMAND A to COMMAND E = 0, DISPLAY1 POWER to DISPLAY4 POWER = -1 |
| Getting example | Command | @GTF,1 ↵ |
| | Response | @GTF,1,-1 ↵ |
| | Description | Getting blinking time of COMMAND A. The switch will be blinked while control command is being executed. |
| Setting example | Command | @STF,1,5 ↵ |
| | Response | @STF,1,5 ↵ |
| | Description | Setting COMMAND A to blink 5 seconds after control command execution starts. |
| Remarks | | — |

3.3.15 Preset memory

| @RCM | | Loading crosspoint memory |
|--------------------|-------------|--|
| Setting | Command | @RCM, memory ↵ |
| | Response | @RCM, memory ↵ |
| Parameter | | memory: Crosspoint memory 1 to 9 |
| Setting example | Command | @RCM,1 ↵ |
| | Response | @RCM,1 ↵ |
| | Description | Loading video and audio channels of crosspoint memory 1. |
| Remarks | | — |

| @SCM / @SEM | | Saving channels to crosspoint memory |
|--------------------|---------------------|---|
| Setting | Description | Overwriting all |
| | Command | @SCM, memory (, name) ↵ |
| | Response | @SCM, memory (, name) ↵ |
| Setting | Description | Overwriting partly |
| | Command | @SEM, memory (, name) ↵ |
| | Response | @SEM, memory (, name) ↵ |
| Parameter | | memory: Crosspoint memory 1 to 9 name: Memory name Up to 10 characters using 20 to 7D from ASCII codes. If you do not specify memory name, only crosspoint settings are saved without changing the current memory name. |
| Setting example | Command Response | @SCM,2 ↵ @SCM,2 ↵ |
| | Description | Saving the current video and audio channels to crosspoint memory 2 without changing the memory name. |
| Setting example | Command Response | @SEM,2,PATTERN2 ↵ @SEM,2,PATTERN2 ↵ |
| | Description | Saving the current video and audio channels to crosspoint memory 2 with the name of "PATTERN2". Output settings that are set to Not Controlled are not saved. |
| Remarks | | — |

| @GCM / @ECM | | Editing crosspoint memory |
|--------------------|-------------|--|
| Getting | Command | @GCM, memory <input type="button" value="↵"/> |
| | Response | @GCM, memory, v_1, a_1, v_2, a_2, v_3, a_3, v_4, a_4, name <input type="button" value="↵"/> |
| Setting | Command | @ECM, memory, v_1, a_1, v_2, a_2, v_3, a_3, v_4, a_4 <input type="button" value="↵"/> |
| | Response | @ECM, memory, v_1, a_1, v_2, a_2, v_3, a_3, v_4, a_4 <input type="button" value="↵"/> |
| Parameter | | memory: Crosspoint memory 1 to 9 |
| | | v_1-4: Video channel a_1-4: Audio channel -1 = Not controlled [Default], 0 = OFF, 1 = IN1 to 8 = IN8 |
| | | name: Memory name Up to 10 characters using 20 to 7D from ASCII codes. [Default] 20 (space) |
| Getting example | Command | @GCM,2 <input type="button" value="↵"/> |
| | Response | @GCM,2,3,3,1,1,-1,-1,-1,-1,PATTERN2 <input type="button" value="↵"/> |
| | Description | Getting the video and audio channels of crosspoint memory 2. OUT1: IN3, OUT2: IN1 are saved with the name of "PATTERN2", OUT3 to OUT4: Not controlled but saved |
| Setting example | Command | @ECM,2,1,1,-1,-1,-1,-1,-1 <input type="button" value="↵"/> |
| | Response | @ECM,2,1,1,-1,-1,-1,-1,-1 <input type="button" value="↵"/> |
| | Description | Setting the crosspoint memory 2 to: OUT1: IN1, OUT2 to OUT4: Not controlled |
| Remarks | | Nothing is saved in the memory by factory default, the state is "-1" (Not controlled). If you save only video (@SCV) or audio (@SCA) at the first saving of crosspoint settings, "-1" (Not controlled) is returned to unsaved audio and video. |

| @RCV | | Loading crosspoint memory (setting video channel) |
|-----------------|-------------|--|
| Setting | Command | @RCV, memory <input type="button" value="↵"/> |
| | Response | @RCV, memory <input type="button" value="↵"/> |
| Parameter | | memory: Crosspoint memory 1 to 9 |
| Getting example | Command | @RCV,1 <input type="button" value="↵"/> |
| | Response | @RCV,1 <input type="button" value="↵"/> |
| | Description | Loading video channel of crosspoint memory 1. |
| Remarks | | — |

| @SCV / @SEV | | Saving crosspoint memory (Setting video channel) |
|--------------------|-------------|---|
| Setting | Description | Overwriting all |
| | Command | @SCV, memory (, name) |
| | Response | @SCV, memory (, name) |
| Setting | Description | Overwriting partly |
| | Command | @SEV, memory (, name) |
| | Response | @SEV, memory (, name) |
| Parameter | | memory: Crosspoint memory 1 to 9 |
| | | name: Memory name Up to 10 characters using 20 to 7D from ASCII codes. If you do not specify memory name, only settings of crosspoint are saved without changing the memory name. |
| Setting example | Command | @SCV,2 |
| | Response | @SCV,2 |
| | Description | Saving the current video channel in crosspoint memory 2 without changing memory name. |
| Setting example | Command | @SEV,2,PATTERN2 |
| | Response | @SEV,2,PATTERN2 |
| | Description | Saving the current video channel in crosspoint memory 2 with the name of "PATTERN2". Output settings that are set to Not Controlled are not saved. |
| Remarks | | — |

| @GCV / @ECV | | Editing crosspoint memory (Setting video channel) |
|--------------------|-------------|--|
| Getting | Command | @GCV, memory |
| | Response | @GCV, memory, v_1, v_2, v_3, v_4, name |
| Setting | Command | @ECV, memory, v_1, v_2, v_3, v_4 |
| | Response | @ECV, memory, v_1, v_2, v_3, v_4 |
| Parameter | | memory: Crosspoint memory 1 to 9 |
| | | v_1-4: Video channel -1 = Not controlled [Default], 0 = OFF, 1 = IN1 to 8 = IN8 |
| | | name: Memory name Up to 10 characters using 20 to 7D from ASCII codes. [Default] 20 (space) |
| Getting example | Command | @GCV,2 |
| | Response | @GCV,2,3,1,1,1,PATTERN2 |
| | Description | Getting video channel of crosspoint memory 2. OUT1: IN3, Other outputs: IN1 are saved with the name of "PATTERN2". |
| Setting example | Command | @ECV,2,1,1,-1,-1 |
| | Response | @ECV,2,1,1,-1,-1 |
| | Description | When crosspoint memory 2 is loaded, OUT1 and OUT2 are set to IN1, OUT3 and OUT4 are set to Not Controlled. |
| Remarks | | Nothing is saved in the memory by factory default, the state is "-1" (Not controlled). If you save only audio (@SCA) at the first saving of crosspoint settings, "-1" (Not controlled) is returned to unsaved audio and video. |

| @RCA | | Loading audio channel setting from crosspoint memory |
|--------------------|-------------|---|
| Setting | Command | @RCA, memory ↵ |
| | Response | @RCA, memory ↵ |
| Parameter | | memory: Crosspoint memory 1 to 9 |
| Setting example | Command | @RCA,1 ↵ |
| | Response | @RCA,1 ↵ |
| | Description | Loading audio channel of crosspoint memory 1. |
| Remarks | | — |

| @SCA / @SEA | | Saving crosspoint memory (Setting audio channel) |
|--------------------|-------------|---|
| Setting | Description | Overwriting all |
| | Command | @SCA, memory, name ↵ |
| | Response | @SCA, memory, name ↵ |
| Setting | Description | Overwriting partly |
| | Command | @SEA, memory (, name) ↵ |
| | Response | @SEA, memory (, name) ↵ |
| Parameter | | memory: Crosspoint memory 1 to 9 name: Memory name Up to 10 characters using 20 to 7D from ASCII codes. If you do not specify memory name, only crosspoint settings are saved without changing the memory name. |
| Setting example | Command | @SCA,2 ↵ |
| | Response | @SCA,2 ↵ |
| | Description | Saving the current audio channel in crosspoint memory 2 without changing memory name. |
| Setting example | Command | @SEA,2,PATTERN2 ↵ |
| | Response | @SEA,2,PATTERN2 ↵ |
| | Description | Saving the current video channel in crosspoint memory 2 with the name of "PATTERN2". Output settings that are set to Not Controlled are not saved. |
| Remarks | | — |

| @GCA / @ECA | | Editing crosspoint memory (Setting audio channel) |
|--------------------|-------------|--|
| Getting | Command | @GCA, memory ↵ |
| | Response | @GCA, memory, a_1, a_2, a_3, a_4, name ↵ |
| Setting | Command | @ECA, memory, a_1, a_2, a_3, a_4 ↵ |
| | Response | @ECA, memory, a_1, a_2, a_3, a_4 ↵ |
| Parameter | | memory: Crosspoint memory 1 to 9 |
| | | a_1-4: Audio channel -1 = Not controlled [Default], 0 = OFF, 1 = IN1 to 8 = IN8 |
| | | name: Memory name Up to 10 characters using 20 to 7D from ASCII codes. [Default] 20 (space) |
| Getting example | Command | @GCA,2 ↵ |
| | Response | @GCA,2,3,3,1,1,PATTERN2 ↵ |
| | Description | Getting audio channel of crosspoint memory 2. OUT1 and OUT2: IN3, OUT3 and OUT4: IN1 are saved with the name of "PATTERN2" |
| Setting example | Command | @ECA,2,1,2,3,4 ↵ |
| | Response | @ECA,2,1,2,3,4 ↵ |
| | Description | When crosspoint memory 2 is loaded, outputs are set as follows: OUT1: IN1, OUT2: IN2, OUT3: IN3, OUT4: audio channel of IN4 |
| Remarks | | Nothing is saved in the memory by factory default, the state is "-1" (Not controlled). If you save only video (@SCV) at the first saving of crosspoint settings, "-1" (Not controlled) is returned to unsaved audio and video. |

| @RPM | | Loading all settings |
|-----------------|-------------|---|
| Setting | Command | @RPM, preset ↵ |
| | Response | @RPM, preset ↵ |
| Parameter | | preset: Preset memory 1 to 12 |
| Setting example | Command | @RPM,3 ↵ |
| | Response | @RPM,3 ↵ |
| | Description | Loading preset memory 3. |
| Remarks | | Once preset memory is loaded, all settings of video and audio I/O except for some environmental settings will be updated. |

| @SPM | | Saving all settings |
|-----------------|-------------|--|
| Setting | Command | @SPM, preset (, name) ↵ |
| | Response | @SPM, preset (, name) ↵ |
| Parameter | | preset: Preset memory 1 to 12 |
| | | name: Memory name Up to 10 characters using 20 to 7D from ASCII codes. If you do not specify memory name, only crosspoint settings are saved without changing the memory name. |
| Setting example | Command | @SPM,2 ↵ |
| | Response | @SPM,2 ↵ |
| | Description | Saving the current settings in preset memory 2 without changing the memory name. |
| Setting example | Command | @SPM,2,MEMORY2 ↵ |
| | Response | @SPM,2,MEMORY2 ↵ |
| | Description | Saving the current settings in preset memory 2 with the name of "MEMORY2". |
| Remarks | | — |

| @SCP | | Copying output setting |
|-----------------|-------------|---|
| Setting | Command | @SCP, out_ori, out_des ↵ |
| | Response | @SCP, out_ori, out_des ↵ |
| Parameter | | out_ori: Source output channel 1 = OUT1 to 4 = OUT4 |
| | | out_des: Destination output channel 1 = OUT1 to 4 = OUT4 |
| Setting example | Command | @SCP,2,1 ↵ |
| | Response | @SCP,2,1 ↵ |
| | Description | Copying OUT2's setting to OUT1. |
| Remarks | | Once output setting is copied, all settings related to output are copied. |

| @GMU / @SMU | | Startup settings |
|--------------------|-------------|---|
| Getting | Command | @GMU ↵ |
| | Response | @GMU, state ↵ |
| Setting | Command | @SMU, state ↵ |
| | Response | @SMU, state ↵ |
| Parameter | | state: Startup settings 1 to 9 = Crosspoint memory 1 to 9, 10 = Channel OFF, 11 = Last channel [Default], 12 to23 = Preset memory 1 to 12 |
| Getting example | Command | @GMU ↵ |
| | Response | @GMU,3 ↵ |
| | Description | Getting settings for startup. Channel settings of crosspoint memory 3. |
| Setting example | Command | @SMU,3 ↵ |
| | Response | @SMU,3 ↵ |
| | Description | Setting startup channel settings to crosspoint memory 3. |
| Remarks | | — |

3.3.16 Bitmap

| @GBM / @SBM | | Outputting bitmap image |
|--------------------|-------------|---|
| Getting | Command | @GBM ↵ |
| | Response | @GBM, out_1, out_2, out_3, out_4 ↵ |
| Setting | Command | @SBM, ch_1, out_1 (, ch_2, out_2···) ↵ |
| | Response | @SBM, ch_1, out_1 (, ch_2, out_2···) ↵ |
| Parameter | | out_1-4: Outputting bitmap image 0 = OFF [Default], 1 = Bitmap 1 ON, 2 = Bitmap 2 ON, 3 = Bitmap 3 ON, 4 = Bitmap 4 ON Only registered numbers can be specified. ch_1-4: Output channel 0 = All outputs, 1 = OUT1 to 4 = OUT4 |
| Getting example | Command | @GBM ↵ |
| | Response | @GBM,1,0,0,0,0,0,0 ↵ |
| | Description | Getting the output image. OUT1: bitmap 1, OUT2 to OUT4: not output a bitmap image. |
| Setting example | Command | @SBM,1,1 ↵ |
| | Response | @SBM,1,1 ↵ |
| | Description | Outputting bitmap 1 image to OUT1. |
| Remarks | | — |

| @GBB / @SBB | | Background color |
|--------------------|-------------|--|
| Getting | Command | @GBB, ch |
| | Response | @GBB, ch, red_1, green_1, blue_1, red_2, green_2, blue_2, red_3, green_3, blue_3, red_4, green_4, blue_4 |
| Setting | Command | @SBB, ch_1, bitmap_1, red_1, green_1, blue_1 (, ch_2, bitmap_2, red_2, green_2, blue_2···) |
| | Response | @SBB, ch_1, bitmap_1, red_1, green_1, blue_1 (, ch_2, bitmap_2, red_2, green_2, blue_2···) |
| Parameter | | ch: Output channel 1 = OUT1 to 4 = OUT4 |
| | | ch_1-4: Output channel 0 = All outputs, 1 = OUT1 to 4 = OUT4 |
| | | red_1-4 : Background color (Red) green_1-4 : Background color (Green) blue_1-4 : Background color (Blue) 0 to 255 [Default] 255 (White) Getting commands: registered bitmap settings is returned in order. |
| | | bitmap_1-4: Bitmap number 0 = All bitmaps, 1 = bitmap 1, 2 = bitmap 2, 3 = bitmap 3, 4 = bitmap 4 Only registered numbers can be specified. |
| | | |
| Getting example | Command | @GBB,2 |
| | Response | @GBB,2,255,0,0,255,0,0,255,0,0,255,0,0 |
| | Description | Getting background color of OUT2. R: 255, G and B: 0 (Red) |
| Setting example | Command | @SBB,1,1,255,255,255 |
| | Response | @SBB,1,1,255,255,255 |
| | Description | Setting background color for when Bitmap 1 is output to OUT1 to 255 for RGB (white). |
| Remarks | | — |

| @GBT / @SBT | | Aspect ratio |
|--------------------|-------------|--|
| Getting | Command | @GBT, ch |
| | Response | @GBT, ch, aspect_1, aspect_2, aspect_3, aspect_4 |
| Setting | Command | @SBT, ch_1, bitmap_1, aspect_1 (, ch_2, bitmap_2, aspect_2···) |
| | Response | @SBT, ch_1, bitmap_1, aspect_1 (, ch_2, bitmap_2, aspect_2···) |
| Parameter | | <p>ch: Output channel 1 = OUT1 to 4 = OUT4</p> <p>ch_1-4: Output channel 0 = All outputs, 1 = OUT1 to 4 = OUT4</p> <p>aspect_1-4: Aspect ratio 0 = AUTO [Default], 1 = FULL, 2 = THROUGH Getting commands: registered bitmap settings is returned in order.</p> <p>bitmap_1-4: Bitmap number 0 = All bitmaps, 1 = bitmap 1, 2 = bitmap 2, 3 = bitmap 3, 4 = bitmap 4 Only registered numbers can be specified.</p> |
| Getting example | Command | @GBT,1 |
| | Response | @GBT,1,1,1,1,1 |
| | Description | Getting aspect ratio of OUT1. Displayed on FULL screen. |
| Setting example | Command | @SBT,1,1,1 |
| | Response | @SBT,1,1,1 |
| | Description | Setting the aspect ratio of bitmap 1 that is output to OUT1 to FLL. |
| Remarks | | — |

| @GZP / @SZP | | Display position |
|--------------------|-------------|---|
| Getting | Command | @GZP, ch |
| | Response | @GZP, ch, position_1, position_2, position_3, position_4 |
| Setting | Command | @SZP, ch_1, bitmap_1, position_1 (, ch_2, bitmap_2, position_2···) |
| | Response | @SZP, ch_1, bitmap_1, position_1 (, ch_2, bitmap_2, position_2···) |
| Parameter | | <p>ch: Output channel 1 = OUT1 to 4 = OUT4</p> <p>ch_1-4: Output channel 0 = All outputs, 1 = OUT1 to 4 = OUT4</p> <p>position_1-4: Display position 0 = CENTER [Default], 1 = TOP-LEFT, 2 = BOTTOM-LEFT, 3 = TOP-RIGHT, 4 = BOTTOM-RIGHT Getting commands: registered bitmap settings is returned in order.</p> <p>bitmap_1-4: Bitmap number 0 = All bitmaps, 1 = Bitmap 1, 2 = Bitmap 2, 3 = Bitmap 3, 4 = Bitmap 4 Only registered numbers can be specified.</p> |
| Getting example | Command | @GZP,1 |
| | Response | @GZP,1,1,1,1,1 |
| | Description | Getting the display position of OUT1. Displaying at TOP-LEFT. |
| Setting example | Command | @SZP,1,1,1 |
| | Response | @SZP,1,1,1 |
| | Description | Setting bitmap 1 that is output from OUT1 to be displayed at TOP-LEFT. |
| Remarks | | — |

| @GBA / @SBA | | Assigning input channel |
|--------------------|-------------|---|
| Getting | Command | @GBA, ch ↵ |
| | Response | @GBA, ch, bitmap_1, bitmap_2, bitmap_3, bitmap_4, ..., bitmap_8 ↵ |
| Setting | Command | @SBA, ch_1, input_1, bitmap_1 (, ch_2, input_2, bitmap_2···) ↵ |
| | Response | @SBA, ch_1, input_1, bitmap_1 (, ch_2, input_2, bitmap_2···) ↵ |
| Parameter | | <p>ch: Output channel 1 = OUT1 to 4 = OUT4</p> <p>ch_1-4: Output channel 0 = All outputs, 1 = OUT1 to 4 = OUT4</p> <p>bitmap_1-8: Bitmap assignment 0 = NONE [Default], 1 = Bitmap 1, 2 = Bitmap 2, 3 = Bitmap 3, 4 = Bitmap 4 Only registered numbers can be specified.</p> <p>input_1-8: Input channel 0 = All inputs, 1 = IN1 to 8 = IN8</p> |
| Getting example | Command | @GBA,1 ↵ |
| | Response | @GBA,1,0,0,0,0,0,0,1,0 ↵ |
| | Description | Getting the OUT1 bitmap assignment. OUT1: bitmap 1 to IN7, other input channels: no bitmap is assigned. |
| Setting example | Command | @SBA,1,7,1 ↵ |
| | Response | @SBA,1,7,1 ↵ |
| | Description | Setting OUT1: Assigning bitmap 1 to IN7 (If IN7 is selected, bitmap 1 is output.) |
| Remarks | | — |

| @GPB / @SPB | | Startup bitmap |
|--------------------|-------------|---|
| Getting | Command | @GPB ↵ |
| | Response | @GPB, out_1, out_2, out_3, out_4 ↵ |
| Setting | Command | @SPB, ch_1, out_1 (, ch_2, out_2···) ↵ |
| | Response | @SPB, ch_1, out_1 (, ch_2, out_2···) ↵ |
| Parameter | | <p>out_1-4: Outputting bitmap image 0 = OFF [Default], 1 = Bitmap 1 ON, 2 = Bitmap 2 ON, 3 = Bitmap 3 ON, 4 = Bitmap 4 ON Only registered numbers can be specified.</p> <p>ch_1-4: Output channel 0 = All outputs, 1 = OUT1 to 4 = OUT4</p> |
| Getting example | Command | @GPB ↵ |
| | Response | @GPB,0,0,1,1 ↵ |
| | Description | Getting the bitmap that is output at startup. Bitmap 1 is output to OUT3 and OUT4. |
| Setting example | Command | @SPB,1,0 ↵ |
| | Response | @SPB,1,0 ↵ |
| | Description | OUT1: not output a bitmap at startup. |
| Remarks | | — |

| @GBD / @SBD | | Dividing memory area |
|--------------------|-------------|--|
| Getting | Command | @GBD |
| | Response | @GBD, num, block_1 (, block_2···) |
| Setting | Command | @SBD, num, mode (, block_1, block_2···) |
| | Response | @SBD, num, mode, block_1 (, block_2···) |
| Parameter | | <p>num: The number of divides 1 to 4 [Default] 1</p> <p>block_1-4: Block size of each memory 0 to 128 [Default] 128 Specify and return the divided block size. 1 block: 65,536 bytes, the total size of all bitmaps: 128 blocks (8,388,608 bytes or smaller) Specify only if “3” is selected for the “mode” below. If you set the divide mode to “3”, specify this value.</p> <p>mode: Divide mode 0 = AUTO, 1 = RESIZE, 2 = FORCE, 3 = Specify size If you select “3”, set <i>size_1-4</i> below.</p> |
| Getting example | Command | @GBD |
| | Response | @GBD,2,64,64 |
| | Description | Getting the divide setting for bitmap memory. Bitmap 1 and bitmap 2: 64 blocks (4,194,304 bytes) are allocated for each. |
| Setting example | Command | @SBD,2,1 |
| | Response | @SBD,2,1,64,64 |
| | Description | Dividing bitmap memory into two in RESIZE mode. Bitmap 1 and bitmap 2: 64 blocks (4,194,304 bytes) are allocated for each. |
| Remarks | | — |

| @GBV | | Memory area status |
|-----------------|-------------|--|
| Getting | Command | @GBV |
| | Response | @GBV, num, block_1 (, block_2···) |
| Parameter | | <p>num: The number of divides 1 to 4 [Default] 1</p> <p>block_1-4: Block size of each memory actually used. 0 to 128 [Default] 128</p> |
| Getting example | Command | @GBV |
| | Response | @GBV,2,32,0 |
| | Description | Getting the actual status of bitmap memory. Bitmap 1: 32 blocks (2,097,152 bytes) are used, bitmap 2: not registered. |
| Remarks | | — |

| @GFZ / @SFZ | | Freeze |
|--------------------|-------------|--|
| Getting | Command | @GFZ ↵ |
| | Response | @GFZ, freeze_1, freeze_2, freeze_3, freeze_4 ↵ |
| Setting | Command | @SFZ, ch_1, freeze_1 (, ch_2, freeze_2···) ↵ |
| | Response | @SFZ, ch_1, freeze_1 (, ch_2, freeze_2···) ↵ |
| Parameter | | freeze_1-4: Setting freeze 0 = OFF [Default], 1 = ON |
| | | ch_1-4: Output channel 0 = All outputs, 1 = OUT1 to 4 = OUT4 |
| Getting example | Command | @GFZ ↵ |
| | Response | @GFZ,1,0,0,0 ↵ |
| | Description | Getting the freeze status. OUT1: input image is frozen and output. |
| Setting example | Command | @SFZ,1,1 ↵ |
| | Response | @SFZ,1,1 ↵ |
| | Description | Freezing the OUT1 image. |
| Remarks | | Images freeze temporarily. When input channel is switched or input signal is changed, the freeze is released automatically and input image is output normally. |

| @CAP | | Capturing input image |
|-----------------|-------------|--|
| Setting | Command | @CAP, ch, bitmap ↵ |
| | Response | @CAP, ch, bitmap ↵ |
| Parameter | | ch: Output channel 1 = OUT1 to 4 = OUT4 |
| | | bitmap: Bitmap number 1 = Bitmap 1, 2 = Bitmap 2, 3 = Bitmap 3, 4 = Bitmap 4 Only the number of divides or less value can be specified. |
| Setting example | Command | @CAP,1,2 ↵ |
| | Response | @CAP,1,2 ↵ |
| | Description | Registering OUT1 input video in bitmap 2. |
| Remarks | | — |

3.3.17 Other settings

| @GLS / @SLS | | Operation lock |
|--------------------|-------------|---|
| Getting | Command | @GLS ↵ |
| | Response | @GLS, lock ↵ |
| Setting | Command | @SLS, lock ↵ |
| | Response | @SLS, lock ↵ |
| Parameter | | lock: Operation lock 0 = Releasing lock [Default], 1 = Locking, 2 = Changing the current setting |
| Getting example | Command | @GLS ↵ |
| | Response | @GLS,1 ↵ |
| | Description | Getting the operation lock status. Front panel keys are locked. |
| Setting example | Command | @SLS,1 ↵ |
| | Response | @SLS,1 ↵ |
| | Description | Enabling operation lock. |
| Remarks | | — |

| @GLM / @SLM | | Setting operation to be locked |
|--------------------|-------------|--|
| Getting | Command | @GLM ↵ |
| | Response | @GLM, channel, menu, preset_load, command, power, out_select ↵ |
| Setting | Command | @SLM, channel, menu, preset_load, command, power, out_select ↵ |
| | Response | @SLM, channel, menu, preset_load, command, power, out_select ↵ |
| Parameter | | channel : Input channel selection key menu : Menu operation key preset_load : Preset load execution command : Control command execution power : Sink device power key out_select : Output channel switching key 0 = Not locked, 1 = Locked [Default] |
| Getting example | Command | @GLM ↵ |
| | Response | @GLM,1,0,0,0,0,0 ↵ |
| | Description | Getting the target keys/operations to be locked. Input channel selection keys are locked. |
| Setting example | Command | @SLM,1,0,0,0,0,0 ↵ |
| | Response | @SLM,1,0,0,0,0,0 ↵ |
| | Description | Setting input channel selection keys to be locked. |
| Remarks | | Setting out_select to 0. |

| @GBZ / @SBZ | | Buzzer |
|--------------------|-------------|--|
| Getting | Command | @GBZ |
| | Response | @GBZ, bz |
| Setting | Command | @SBZ, bz |
| | Response | @SBZ, bz |
| Parameter | | bz : Buzzer sound 0 = OFF, 1 = ON [Default] |
| Getting example | Command | @GBZ |
| | Response | @GBZ,1 |
| | Description | Getting the buzzer status. ON |
| Setting example | Command | @SBZ,1 |
| | Response | @SBZ,1 |
| | Description | Enabling buzzer. |
| Remarks | | — |

| @GHP / @SHP | | Power supply of HDBaseT input |
|--------------------|-------------|--|
| Getting | Command | @GHP |
| | Response | @GHP, mode_1, mode_2 |
| Setting | Command | @SHP, ch_1, mode_1 (, ch_2, mode_2···) |
| | Response | @SHP, ch_1, mode_1 (, ch_2, mode_2···) |
| Parameter | | ch_1-2: Input channel 5 = IN5, 6 = IN6 |
| | | mode_1-2: Power supply 0 = OFF [Default], 1 = ON |
| Getting example | Command | @GHP |
| | Response | @GHP,0,0 |
| | Description | Getting the power supply setting of HDBaseT input. Power supply of HDBaseT input is set to OFF. |
| Setting example | Command | @SHP,5,1 |
| | Response | @SHP,5,1 |
| | Description | Power supply of IN5 is set to ON. |
| Remarks | | — |

| @GSS | | I/O status | | | | | | | | | | | | | | | | |
|-----------|--|---|-------|-------------------|-----|--|---|---------------------|---|----------------------------|---|------------------------------|---|--|---|--------------------------------|---|--------------------|
| Getting | Command | @GSS, channel, mode ↵ | | | | | | | | | | | | | | | | |
| | Response | @GSS, channel, mode, status_1 (, status_2···) ↵ | | | | | | | | | | | | | | | | |
| Parameter | | <p>channel: I/O channel 1 = IN1 to 8 = IN8 11 = OUT1 to 14 = OUT4</p> <p>mode: Target status</p> <p>channel = 1 to 8 (Digital input channel): 0 = All of 1 to 4, 1 = Input signal type^{*1}, 2 = Video input signal format^{*2}, 3 = Audio input signal format^{*3}, 4 = HDCP input^{*4}</p> <p>channel = 7 to 8 (Analog input channel): 0 = 1 and 2, 1 = Input signal type^{*1}, 2 = Video input signal format^{*2}</p> <p>channel = 11 to 14 (Output channel): 0 = All of 1 to 3, 1 = HDCP authentication status^{*4}, 2 = Output signal type^{*5}, 3 = Error code^{*6}</p> <p>status_1-4: Status</p> <p>^{*1} One of the following values is returned.</p> <table border="1"> <thead> <tr> <th>Value</th> <th>Input signal type</th> </tr> </thead> <tbody> <tr> <td>Hxx</td> <td>HDMI signal is input. xx stands for color depth which is 24 or 30.</td> </tr> <tr> <td>D</td> <td>DVI signal is input</td> </tr> <tr> <td>R</td> <td>Analog RGB signal is input</td> </tr> <tr> <td>Y</td> <td>Analog YPbPr signal is input</td> </tr> <tr> <td>V</td> <td>Analog composite video signal is input</td> </tr> <tr> <td>S</td> <td>Analog S-video signal is input</td> </tr> <tr> <td>N</td> <td>No signal is input</td> </tr> </tbody> </table> | Value | Input signal type | Hxx | HDMI signal is input. xx stands for color depth which is 24 or 30. | D | DVI signal is input | R | Analog RGB signal is input | Y | Analog YPbPr signal is input | V | Analog composite video signal is input | S | Analog S-video signal is input | N | No signal is input |
| Value | Input signal type | | | | | | | | | | | | | | | | | |
| Hxx | HDMI signal is input. xx stands for color depth which is 24 or 30. | | | | | | | | | | | | | | | | | |
| D | DVI signal is input | | | | | | | | | | | | | | | | | |
| R | Analog RGB signal is input | | | | | | | | | | | | | | | | | |
| Y | Analog YPbPr signal is input | | | | | | | | | | | | | | | | | |
| V | Analog composite video signal is input | | | | | | | | | | | | | | | | | |
| S | Analog S-video signal is input | | | | | | | | | | | | | | | | | |
| N | No signal is input | | | | | | | | | | | | | | | | | |

| @GSS | I/O status (cont'd) | | | | | | | | | | | | | |
|---|---|--|------------------------------|------------------------------------|---|-----------------------------------|--|--|--|--|--|------------------------------|--------------------------|-------------------------------|
| Parameter | *2 For format of video input signal. | | | | | | | | | | | | | |
| | <table border="1"> <thead> <tr> <th data-bbox="443 271 721 309">Reply example</th> <th data-bbox="721 271 1410 309">Format of video input signal</th> </tr> </thead> <tbody> <tr> <td data-bbox="443 309 721 376">1080i 59.94Hz</td> <td data-bbox="721 309 1410 376">SDTV/HDTV signal is input, which replies the format type and vertical synchronous frequency</td> </tr> <tr> <td data-bbox="443 376 721 472">800 x 600 60.00Hz</td> <td data-bbox="721 376 1410 472">RGB signal is input, and [Horizontal resolution x Vertical resolution and vertical synchronous frequency] is returned.</td> </tr> <tr> <td data-bbox="443 472 721 533">NTSC</td> <td data-bbox="721 472 1410 533">Analog composite video signal or analog S-video signal is input, which replies the format type.</td> </tr> <tr> <td data-bbox="443 533 721 593">56.83kHz 60.02Hz</td> <td data-bbox="721 533 1410 593">Undetectable signal is input, which replies the horizontal and vertical synchronous frequencies.</td> </tr> <tr> <td data-bbox="443 593 721 636">NO SIGNAL</td> <td data-bbox="721 593 1410 636">No video signal is input</td> </tr> </tbody> </table> | Reply example | Format of video input signal | 1080i 59.94Hz | SDTV/HDTV signal is input, which replies the format type and vertical synchronous frequency | 800 x 600 60.00Hz | RGB signal is input, and [Horizontal resolution x Vertical resolution and vertical synchronous frequency] is returned. | NTSC | Analog composite video signal or analog S-video signal is input, which replies the format type. | 56.83kHz 60.02Hz | Undetectable signal is input, which replies the horizontal and vertical synchronous frequencies. | NO SIGNAL | No video signal is input | |
| | Reply example | Format of video input signal | | | | | | | | | | | | |
| | 1080i 59.94Hz | SDTV/HDTV signal is input, which replies the format type and vertical synchronous frequency | | | | | | | | | | | | |
| | 800 x 600 60.00Hz | RGB signal is input, and [Horizontal resolution x Vertical resolution and vertical synchronous frequency] is returned. | | | | | | | | | | | | |
| | NTSC | Analog composite video signal or analog S-video signal is input, which replies the format type. | | | | | | | | | | | | |
| | 56.83kHz 60.02Hz | Undetectable signal is input, which replies the horizontal and vertical synchronous frequencies. | | | | | | | | | | | | |
| | NO SIGNAL | No video signal is input | | | | | | | | | | | | |
| | *3 Format of audio input signal. | | | | | | | | | | | | | |
| | <table border="1"> <thead> <tr> <th data-bbox="443 712 721 750">Reply example</th> <th data-bbox="721 712 1410 750">Format of audio input signal</th> </tr> </thead> <tbody> <tr> <td data-bbox="443 750 721 817">LINEAR PCM 48kHz</td> <td data-bbox="721 750 1410 817">Linear PCM signal is input, which replies the sampling frequency.</td> </tr> <tr> <td data-bbox="443 817 721 898">LINEAR PCM 48kHz (MULTI CHANNEL)</td> <td data-bbox="721 817 1410 898">Multi channel linear PCM signal is input.</td> </tr> <tr> <td data-bbox="443 898 721 1021">COMPRESSED AUDIO</td> <td data-bbox="721 898 1410 1021">Compressed audio signal (such as Dolby Digital and DTS) is input (The MSD does not recognize detailed formats. "COMPRESSED AUDIO" is sent to all compressed audios).</td> </tr> <tr> <td data-bbox="443 1021 721 1061">NO SIGNAL</td> <td data-bbox="721 1021 1410 1061">No video signal is input.</td> </tr> </tbody> </table> | Reply example | Format of audio input signal | LINEAR PCM 48kHz | Linear PCM signal is input, which replies the sampling frequency. | LINEAR PCM 48kHz (MULTI CHANNEL) | Multi channel linear PCM signal is input. | COMPRESSED AUDIO | Compressed audio signal (such as Dolby Digital and DTS) is input (The MSD does not recognize detailed formats. "COMPRESSED AUDIO" is sent to all compressed audios). | NO SIGNAL | No video signal is input. | | | |
| | Reply example | Format of audio input signal | | | | | | | | | | | | |
| | LINEAR PCM 48kHz | Linear PCM signal is input, which replies the sampling frequency. | | | | | | | | | | | | |
| | LINEAR PCM 48kHz (MULTI CHANNEL) | Multi channel linear PCM signal is input. | | | | | | | | | | | | |
| | COMPRESSED AUDIO | Compressed audio signal (such as Dolby Digital and DTS) is input (The MSD does not recognize detailed formats. "COMPRESSED AUDIO" is sent to all compressed audios). | | | | | | | | | | | | |
| | NO SIGNAL | No video signal is input. | | | | | | | | | | | | |
| *4 HDCP authentication | | | | | | | | | | | | | | |
| <table border="1"> <thead> <tr> <th data-bbox="443 1137 721 1176">Reply example</th> <th data-bbox="721 1137 1410 1176">HDCP authentication</th> </tr> </thead> <tbody> <tr> <td data-bbox="443 1176 721 1227">HDCP1.4 SUPPORT</td> <td data-bbox="721 1176 1410 1227">Device with HDCP 1.4 is connected.</td> </tr> <tr> <td data-bbox="443 1227 721 1308">HDCP NOT SUPPORT</td> <td data-bbox="721 1227 1410 1308">Device without HDCP is connected.</td> </tr> <tr> <td data-bbox="443 1308 721 1368">HDCP ERROR</td> <td data-bbox="721 1308 1410 1368">Device with HDCP is connected, but the authorization failed.</td> </tr> <tr> <td data-bbox="443 1368 721 1429">HDCP CHECK NOW</td> <td data-bbox="721 1368 1410 1429">Connection status of sink device was changed, and the status is being checked.</td> </tr> <tr> <td data-bbox="443 1429 721 1509">MONITOR DISCONNECT</td> <td data-bbox="721 1429 1410 1509">Sink device is disconnected.</td> </tr> <tr> <td data-bbox="443 1509 721 1547">UNCONNECTED</td> <td data-bbox="721 1509 1410 1547">Sink device is not connected.</td> </tr> </tbody> </table> | Reply example | HDCP authentication | HDCP1.4 SUPPORT | Device with HDCP 1.4 is connected. | HDCP NOT SUPPORT | Device without HDCP is connected. | HDCP ERROR | Device with HDCP is connected, but the authorization failed. | HDCP CHECK NOW | Connection status of sink device was changed, and the status is being checked. | MONITOR DISCONNECT | Sink device is disconnected. | UNCONNECTED | Sink device is not connected. |
| Reply example | HDCP authentication | | | | | | | | | | | | | |
| HDCP1.4 SUPPORT | Device with HDCP 1.4 is connected. | | | | | | | | | | | | | |
| HDCP NOT SUPPORT | Device without HDCP is connected. | | | | | | | | | | | | | |
| HDCP ERROR | Device with HDCP is connected, but the authorization failed. | | | | | | | | | | | | | |
| HDCP CHECK NOW | Connection status of sink device was changed, and the status is being checked. | | | | | | | | | | | | | |
| MONITOR DISCONNECT | Sink device is disconnected. | | | | | | | | | | | | | |
| UNCONNECTED | Sink device is not connected. | | | | | | | | | | | | | |

| @GSS | I/O status (cont'd) | | | | | | | | | | | | | | | | | | | | | | | | | | | | | | | | |
|------------|---|--|-----------------------|---------------------|---|---|----------------------|---|---|---|------------------------------|--|-------------------------------------|---|---------------------------|---|---|--|--|---|---|--|---|--|--|---|--|--|---|---|---|---|---|
| Parameter | * ⁵ Type of output signal. | | | | | | | | | | | | | | | | | | | | | | | | | | | | | | | | |
| | <table border="1"> <thead> <tr> <th data-bbox="443 275 592 353">Reply example</th> <th data-bbox="598 275 1430 353">Type of output signal</th> </tr> </thead> <tbody> <tr> <td data-bbox="443 362 592 394">Hxx</td> <td data-bbox="598 362 1430 394">HDMI signal is output. xx stands for the color depth, 24 or 30.</td> </tr> <tr> <td data-bbox="443 403 592 434">D</td> <td data-bbox="598 403 1430 434">DVI signal is input.</td> </tr> <tr> <td data-bbox="443 443 592 474">C</td> <td data-bbox="598 443 1430 474">HDCP is being authorized. No video is output.</td> </tr> <tr> <td data-bbox="443 483 592 515">N</td> <td data-bbox="598 483 1430 515">No sink device is connected.</td> </tr> <tr> <td data-bbox="443 524 592 555">O</td> <td data-bbox="598 524 1430 555">No twisted pair cable is connected.</td> </tr> </tbody> </table> | Reply example | Type of output signal | Hxx | HDMI signal is output. xx stands for the color depth, 24 or 30. | D | DVI signal is input. | C | HDCP is being authorized. No video is output. | N | No sink device is connected. | O | No twisted pair cable is connected. | | | | | | | | | | | | | | | | | | | | |
| | Reply example | Type of output signal | | | | | | | | | | | | | | | | | | | | | | | | | | | | | | | |
| | Hxx | HDMI signal is output. xx stands for the color depth, 24 or 30. | | | | | | | | | | | | | | | | | | | | | | | | | | | | | | | |
| | D | DVI signal is input. | | | | | | | | | | | | | | | | | | | | | | | | | | | | | | | |
| | C | HDCP is being authorized. No video is output. | | | | | | | | | | | | | | | | | | | | | | | | | | | | | | | |
| | N | No sink device is connected. | | | | | | | | | | | | | | | | | | | | | | | | | | | | | | | |
| | O | No twisted pair cable is connected. | | | | | | | | | | | | | | | | | | | | | | | | | | | | | | | |
| | * ⁶ Error codes below are returned in the following order: video output to HDMI output connector / audio output to HDMI output connector / audio output to audio output connector. | | | | | | | | | | | | | | | | | | | | | | | | | | | | | | | | |
| | <table border="1"> <thead> <tr> <th data-bbox="443 710 592 741">Error code</th> <th data-bbox="598 710 991 741">Video output status</th> <th data-bbox="997 710 1430 741">Audio output status</th> </tr> </thead> <tbody> <tr> <td data-bbox="443 750 592 781">0</td> <td colspan="2" data-bbox="598 750 1430 781">Video or audio is output correctly.*⁷</td> </tr> <tr> <td data-bbox="443 790 592 822">1</td> <td data-bbox="598 790 991 822">—</td> <td data-bbox="997 790 1430 822">“@GAM / @SAM Audio output mute” is set to “ON”.</td> </tr> <tr> <td data-bbox="443 831 592 862">2</td> <td colspan="2" data-bbox="598 831 1430 987">Only digital input is returned, which means DDC power is not input. (When no source device is connected, this error code is normally displayed.)</td> </tr> <tr> <td data-bbox="443 996 592 1028">3</td> <td data-bbox="598 996 991 1028">No video signal is input.</td> <td data-bbox="997 996 1430 1028">No audio signal is input.*⁷</td> </tr> <tr> <td data-bbox="443 1037 592 1068">4</td> <td colspan="2" data-bbox="598 1037 1430 1104">Only digital input is returned, which means video or audio output of the source device is muted.</td> </tr> <tr> <td data-bbox="443 1113 592 1144">5</td> <td colspan="2" data-bbox="598 1113 1430 1225">Only digital input is returned, which means signal with HDCP is input but sink device is HDCP incompliant (This error code may be also returned during HDCP authentication)</td> </tr> <tr> <td data-bbox="443 1234 592 1265">6</td> <td colspan="2" data-bbox="598 1234 1430 1339">Only digital input is returned, which means source device does not output the returned information (packets) for output of video or audio.</td> </tr> <tr> <td data-bbox="443 1348 592 1379">7</td> <td data-bbox="598 1348 991 1453">Signal that is not supported by MSD series (dot clock is out of range) is input.</td> <td data-bbox="997 1348 1430 1498">Since compressed audio is input, audio cannot be output (Compressed audio can be output only to sink devices supporting compressed audio).</td> </tr> <tr> <td data-bbox="443 1507 592 1538">8</td> <td data-bbox="598 1507 991 1538">—</td> <td data-bbox="997 1507 1430 1538">—</td> </tr> <tr> <td data-bbox="443 1547 592 1579">9</td> <td data-bbox="598 1547 991 1579">—</td> <td data-bbox="997 1547 1430 1697">“@GDM / @SDM Output mode” is set to “DVI MODE” or a sink device that does not support audio is connected.*⁸</td> </tr> </tbody> </table> | Error code | Video output status | Audio output status | 0 | Video or audio is output correctly.* ⁷ | | 1 | — | “@GAM / @SAM Audio output mute” is set to “ON”. | 2 | Only digital input is returned, which means DDC power is not input. (When no source device is connected, this error code is normally displayed.) | | 3 | No video signal is input. | No audio signal is input.* ⁷ | 4 | Only digital input is returned, which means video or audio output of the source device is muted. | | 5 | Only digital input is returned, which means signal with HDCP is input but sink device is HDCP incompliant (This error code may be also returned during HDCP authentication) | | 6 | Only digital input is returned, which means source device does not output the returned information (packets) for output of video or audio. | | 7 | Signal that is not supported by MSD series (dot clock is out of range) is input. | Since compressed audio is input, audio cannot be output (Compressed audio can be output only to sink devices supporting compressed audio). | 8 | — | — | 9 | — |
| Error code | Video output status | Audio output status | | | | | | | | | | | | | | | | | | | | | | | | | | | | | | | |
| 0 | Video or audio is output correctly.* ⁷ | | | | | | | | | | | | | | | | | | | | | | | | | | | | | | | | |
| 1 | — | “@GAM / @SAM Audio output mute” is set to “ON”. | | | | | | | | | | | | | | | | | | | | | | | | | | | | | | | |
| 2 | Only digital input is returned, which means DDC power is not input. (When no source device is connected, this error code is normally displayed.) | | | | | | | | | | | | | | | | | | | | | | | | | | | | | | | | |
| 3 | No video signal is input. | No audio signal is input.* ⁷ | | | | | | | | | | | | | | | | | | | | | | | | | | | | | | | |
| 4 | Only digital input is returned, which means video or audio output of the source device is muted. | | | | | | | | | | | | | | | | | | | | | | | | | | | | | | | | |
| 5 | Only digital input is returned, which means signal with HDCP is input but sink device is HDCP incompliant (This error code may be also returned during HDCP authentication) | | | | | | | | | | | | | | | | | | | | | | | | | | | | | | | | |
| 6 | Only digital input is returned, which means source device does not output the returned information (packets) for output of video or audio. | | | | | | | | | | | | | | | | | | | | | | | | | | | | | | | | |
| 7 | Signal that is not supported by MSD series (dot clock is out of range) is input. | Since compressed audio is input, audio cannot be output (Compressed audio can be output only to sink devices supporting compressed audio). | | | | | | | | | | | | | | | | | | | | | | | | | | | | | | | |
| 8 | — | — | | | | | | | | | | | | | | | | | | | | | | | | | | | | | | | |
| 9 | — | “@GDM / @SDM Output mode” is set to “DVI MODE” or a sink device that does not support audio is connected.* ⁸ | | | | | | | | | | | | | | | | | | | | | | | | | | | | | | | |

| @GSS | | I/O status (cont'd) | | | | | | | | | | | | | | | |
|-----------------|---|---|------------|---------------------|---------------------|---|---|--|---|------------------------------|--|---|---------------------------|--|---|-----------------------------|--|
| Parameter | | <table border="1"> <thead> <tr> <th>Error code</th> <th>Video output status</th> <th>Audio output status</th> </tr> </thead> <tbody> <tr> <td>A</td> <td colspan="2">Input channel is set to "OFF". (@GSW / @SSW Switching video and audio channel simultaneously, @GSV / @SSVSwitching video channel, @GSA / @SSASwitching audio channel,)</td> </tr> <tr> <td>B</td> <td colspan="2">No sink device is connected.</td> </tr> <tr> <td>C</td> <td colspan="2">HDCP is being authorized.</td> </tr> <tr> <td>D</td> <td colspan="2">HDCP authentication failed.</td> </tr> </tbody> </table> <p>⁷ Analog audio input status cannot be detected. Even if "0" is returned, audio may not be output with analog input selected.</p> | Error code | Video output status | Audio output status | A | Input channel is set to "OFF". (@GSW / @SSW Switching video and audio channel simultaneously, @GSV / @SSV Switching video channel, @GSA / @SSA Switching audio channel,) | | B | No sink device is connected. | | C | HDCP is being authorized. | | D | HDCP authentication failed. | |
| Error code | Video output status | Audio output status | | | | | | | | | | | | | | | |
| A | Input channel is set to "OFF". (@GSW / @SSW Switching video and audio channel simultaneously, @GSV / @SSV Switching video channel, @GSA / @SSA Switching audio channel,) | | | | | | | | | | | | | | | | |
| B | No sink device is connected. | | | | | | | | | | | | | | | | |
| C | HDCP is being authorized. | | | | | | | | | | | | | | | | |
| D | HDCP authentication failed. | | | | | | | | | | | | | | | | |
| Getting example | Command | @GSS,1,0 ↵ | | | | | | | | | | | | | | | |
| | Response | @GSS,1,0,H30,1080P 60Hz,LINEAR PCM 48kHz,HDCP ON ↵ | | | | | | | | | | | | | | | |
| | Description | Getting IN1 all statuses. <ul style="list-style-type: none"> • Input signal type: 30-BIT COLOR HDMI signal • Video input signal: 1080P 60Hz • Audio input signal: LINEAR PCM 48kHz • HDCP: ON | | | | | | | | | | | | | | | |
| Remarks | | — | | | | | | | | | | | | | | | |

| @GES | | Monitor's EDID |
|-----------------|-------------|---|
| Getting | Command | @GES, channel, mode ↵ |
| | Response | @GES, channel, mode, status_1 (, status_2, status_3···) ↵ |
| Parameter | | <p>channel: Output connector 1 = OUT1 to 8 = OUT8</p> <p>mode: Statuses to be gotten 0 = All of 1 to 4, 1 = Monitor's name, 2 = Resolution and dot clock, 3 = HDMI support status, sampling structure, and color depth*¹, 4 = Audio support status and sampling frequency, bit length, the number of channels, and support status of compressed audio *²</p> <p>status_1-4: Status</p> <p>*¹ For sink device that does not support HDMI, "DVI" is returned. For sink device that supports HDMI, "HDMI" is returned, and then supported sampling structures (RGB, YCbCr 4: 2: 2, YCbCr 4: 4: 4, and YCbCr 4: 2: 0, separated with "/") and supported color depths (24, 30, and 36, separated with "/") are replied in that order.</p> <p>*² For sink device that does not support audio, "AUDIO NOT SUPPORT" is returned. For sink device that supports audio, "LINEAR PCM" is returned, and then supported sampling frequencies (32, 44.1, 48, 88.2, 96, 176.4, and 192, separated with "/"), bit length (16, 20, and 24, separated with "/"), the number of channels (one of 1 to 8), and "COMPRESSED AUDIO SUPPORT" (if compressed audio is supported) are replied in that order.</p> |
| Getting example | Command | @GES,1,0 ↵ |
| | Response | @GES,1,0,MSD-6204,1920x1080 148.50MHz,DVI,AUDIO NOT SUPPORT ↵ |
| | Description | <p>Getting the EDID of the sink device connected to OUT1.</p> <ul style="list-style-type: none"> • Monitor name: MSD-6204 • Resolution: 1920x1080 • Dot clock: 148.50 MHz • HDMI: Not supported • Audio: Not supported |
| Remarks | | — |

| @GIV | | Version |
|-----------------|-------------|--|
| Getting | Command | @GIV ↵ |
| | Response | @GIV, id, ver ↵ |
| Parameter | | <p>id : Model number ver : Firmware version</p> |
| Getting example | Command | @GIV ↵ |
| | Response | @GIV,MSD-6204,1.00 ↵ |
| | Description | <p>Getting the product information. Model number and firmware version are replied.</p> |
| Remarks | | — |

User Guide (Command Guide) of MSD-62 Series

Ver.1.3.0

Issued on: 24 April 2023



Headquarters

IDK Corporation
7-9-1 Chuo, Yamato-shi, Kanagawa-pref.
242-0021 JAPAN
TEL: +81-46-200-0764 FAX: +81-46-200-0765

Email: idk_eng@idk.co.jp

URL: www.idkav.com

USA

IDK America Inc.
72 Grays Bridge Road Suite 1-C, Brookfield, CT 06804
TEL: +1-203-204-2445

Email: sales@idkav.com

URL: www.idkav.com

Europe

IDK Europe GmbH
Lise-Meitner-Str. 6, D-40878 Ratingen
TEL: +49-2102-578-301-0

Email: info@idkav.eu

URL: www.idkav.com



Product information Support

Arvanics Corporation
7-9-1 Chuo, Yamato-shi, Kanagawa-pref.
242-0021 JAPAN
TEL: +81-46-259-6920 FAX: +81-46-259-6930

Email: info@arvanics.com

URL: www.arvanics.com

Information in this document is subject to change without notice.

©2018 IDK Corporation, all rights reserved. All trademarks mentioned are the property of their respective owners.